

FDA-series

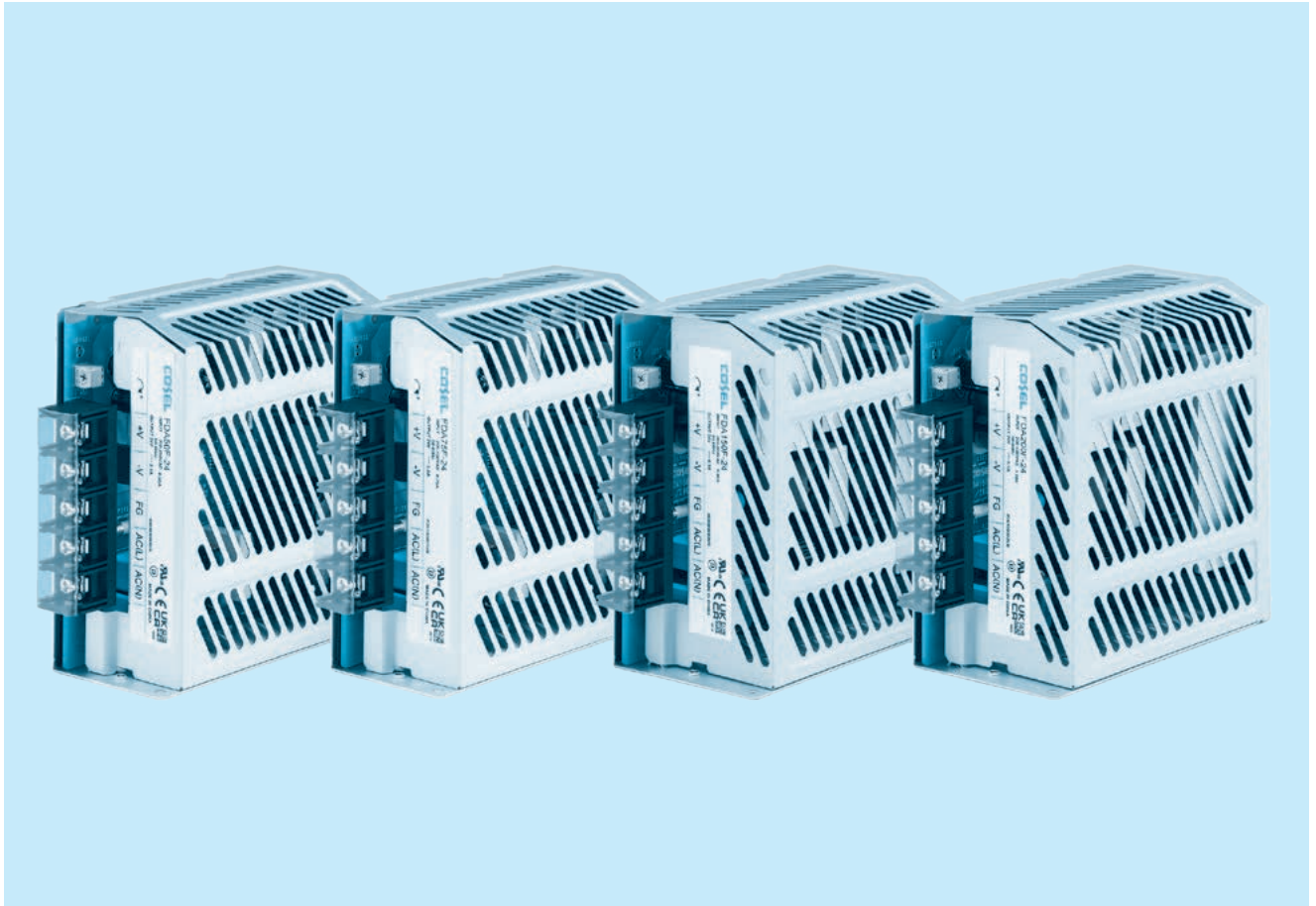

■ Feature

High efficiency
 Complies with SEMI F47
 Harmonic attenuator (Complies with IEC61000-3-2)
 Wide input voltage range : 1 Φ 180•528VAC
 Built-in inrush current, overcurrent and overvoltage protection circuits
 Power factor correction (150W/200W)

■ Safety agency approvals

UL62368-1, C-UL (equivalent to CAN/CSA-C22.2 No.62368-1), EN62368-1

■ 5-year warranty (refer to Instruction Manual)

■ CE marking

Low Voltage Directive
 RoHS Directive

■ UKCA marking

Electrical Equipment Safety Regulations
 RoHS Regulations

■ EMI

Complies with CISPR11-A, CISPR32-A, EN55011-A, EN55032-A, FCC Part 15-A, FCC Part 18-A, VCCI-A

■ EMS Compliance : EN61204-3, EN61000-6-2

EN61000-4-2
 EN61000-4-3
 EN61000-4-4
 EN61000-4-5
 EN61000-4-6
 EN61000-4-8
 EN61000-4-11

FDA50F

① **FD** ② **A** ③ **50** ④ **F** ⑤ **-□** ⑥ **-□**



- ① Series name
- ② Single output
- ③ Output wattage
- ④ Full range input
- ⑤ Output voltage
- ⑥ Optional *1
C: with Coating
N1: with DIN rail
L: with operation LED

For option details, refer to Instruction Manual 5.1.

MODEL	FDA50F-24
MAX OUTPUT WATTAGE[W]	*2 50.4
DC OUTPUT	*2 24V 2.1A

SPECIFICATIONS

	MODEL	FDA50F-24
INPUT	VOLTAGE	[VAC] *2 180 - 528 1 φ (Refer to "Derating" and Instruction Manual 1.1) [VDC] *3 255 - 746
	CURRENT[A]	ACIN 200V 0.50typ (47 - 63Hz) ACIN 400V 0.30typ (47 - 63Hz)
	FREQUENCY[Hz]	50 / 60 (47 - 440)
	EFFICIENCY[%]	ACIN 200V 87typ ACIN 400V 86typ
	INRUSH CURRENT[A]	ACIN 200V 25typ (I _o =100%) at cold start ACIN 400V 50typ (I _o =100%) at cold start
	LEAKAGE CURRENT[mA]	0.75max (ACIN 480V 60Hz, I _o =100%, According to IEC62368-1)
	OUTPUT	VOLTAGE[V]
CURRENT[A]		2.1
LINE REGULATION[mV]		*4 96max
LOAD REGULATION[mV]		*4 150max
RIPPLE[mVp-p]		0 to +50°C 240max -20 to 0°C 320max
RIPPLE NOISE[mVp-p]		0 to +50°C 680max -20 to 0°C 720max
TEMPERATURE REGULATION[mV]		-20 to +50°C 600max
DRIFT[mV]		*6 100max
START-UP TIME[ms]		800max
HOLD-UP TIME[ms]		20typ (ACIN 200V, I _o =100%) / 30typ (ACIN 240V, I _o =100%) / 100typ (ACIN 400V, I _o =100%)
OUTPUT VOLTAGE ADJUSTMENT RANGE[V]		21.60 to 26.40
OUTPUT VOLTAGE SETTING[V]		24.00 to 24.96
PROTECTION CIRCUIT AND OTHERS	OVERCURRENT PROTECTION	Works over 105% of rating and recovers automatically
	OVERVOLTAGE PROTECTION	27.60 to 33.60
	REMOTE SENSING	Not provided
ISOLATION	INPUT-OUTPUT	4,243VAC 1minute, Cutoff current = 10mA, 500VDC 50MΩ min (At Room Temperature)
	INPUT-FG	2,829VAC 1minute, Cutoff current = 10mA, 500VDC 50MΩ min (At Room Temperature)
	OUTPUT-FG	500VAC 1minute, Cutoff current = 25mA, 500VDC 50MΩ min (At Room Temperature)
ENVIRONMENT	OPERATING TEMP., HUMID. AND ALTITUDE *2	-20 to +70°C, 20 - 90%RH (Non condensing) 5,000m (16,500feet) max
	STORAGE TEMP., HUMID. AND ALTITUDE	-20 to +75°C, 20 - 90%RH (Non condensing) 5,000m (16,500feet) max
	VIBRATION	10 - 55Hz, 19.6m/s ² (2G), 3minutes period, 60minutes each along X, Y and Z axis
	IMPACT	196.1m/s ² (20G), 11ms, once each X, Y and Z axis
SAFETY AND NOISE REGULATIONS	AGENCY APPROVALS	UL62368-1, C-UL (equivalent to CAN/CSA-C22.2No.62368-1), EN62368-1
	CONDUCTED NOISE	Complies with CISPR11-A, CISPR32-A, EN55011-A, EN55032-A, FCC Part15-A, FCC Part18-A, VCCI-A
	HARMONIC ATTENUATOR *7	Complies with IEC61000-3-2 (Class A) (No built-in power factor correction)
OTHERS	CASE SIZE/WEIGHT	50 X 125 X 124mm [1.97 X 4.92 X 4.88 inches] (without terminal block) (W X H X D) / 550g max
	COOLING METHOD *2	Convection (Refer to "Derating")

*1 The listed options may affect the published standard specifications. Please contact us for detailed product specifications.
 *2 Derating is required.
 *3 Safety agency approvals are not applicable for DC input.
 *4 At low load conditions, the burst mode operation will start. To check load regulation, you will need to measure the characteristics at average mode with instruments.
 *5 This is the value that measured on measuring board with capacitor of 22 μF and 0.1 μF at 150mm from output terminal. Measured by 20MHz oscilloscope or Ripple-Noise meter (Equivalent to KEISOKU-GIKEN:RM104). Ripple and ripple noise spec is change at I_o=0 to 15% by burst operation.
 *6 Drift is the change in DC output for an eight hours period after a half-hour warm-up at 25°C.
 *7 Please contact us about another class. When two or more units are operating it may not comply with the IEC61000-3-2. Please contact us for details.
 * Do not use the power supply in overcurrent conditions or in unspecified input voltage ranges. Otherwise the internal components may be damaged.
 * Parallel operation is not possible.
 * Sound noise may be generated by power supply in case of pulse load.

Block diagram

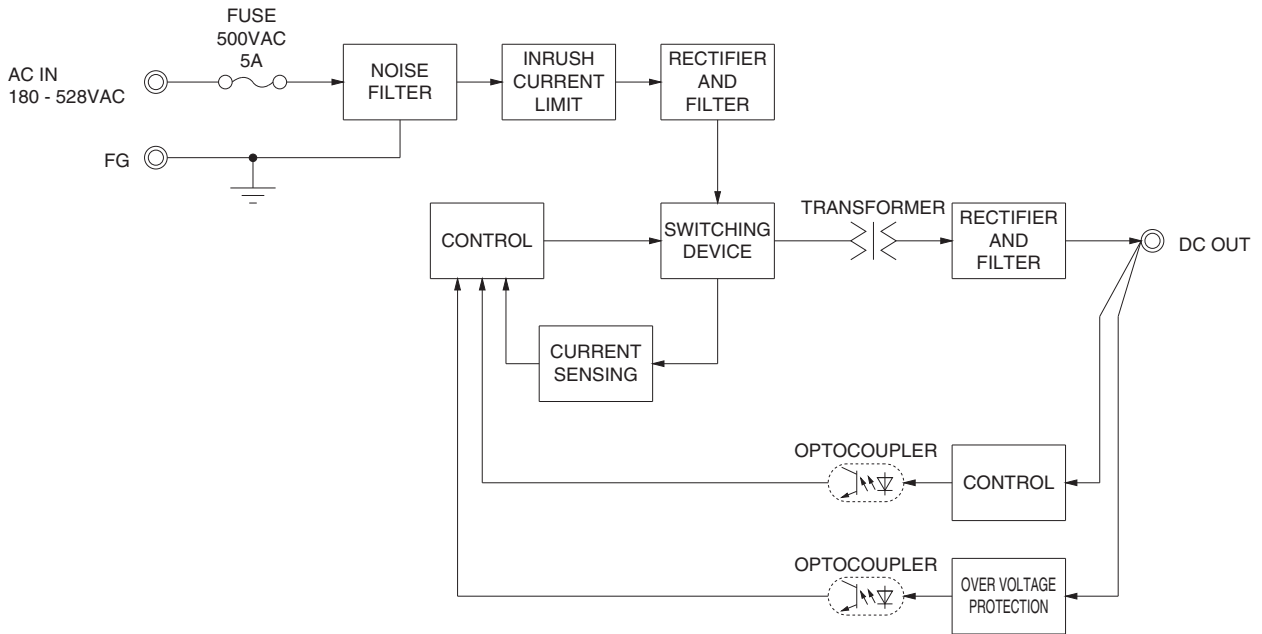

External view

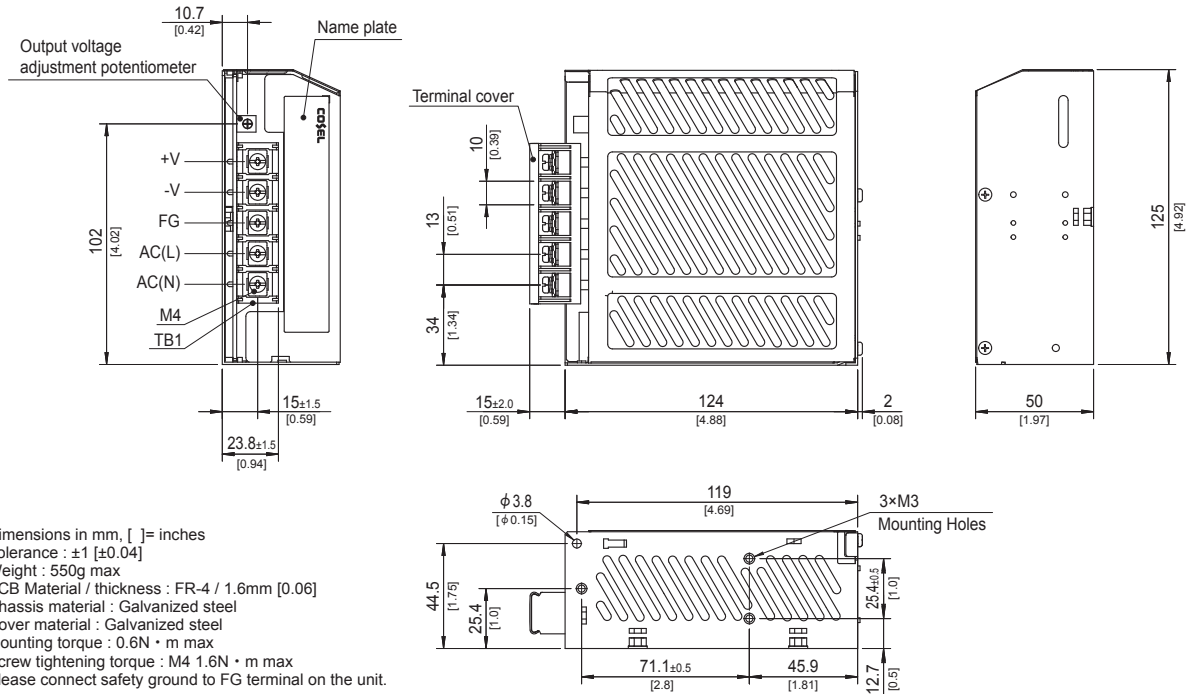

FDA75F

① **FD** ② **A** ③ **75** ④ **F** ⑤ **-□** ⑥ **-□**



- ① Series name
- ② Single output
- ③ Output wattage
- ④ Full range input
- ⑤ Output voltage
- ⑥ Optional *1
 C: with Coating
 N1: with DIN rail
 L: with operation LED

For option details, refer to Instruction Manual 5.1.

MODEL	FDA75F-24
MAX OUTPUT WATTAGE[W]	*2 76.8
DC OUTPUT	*2 24V 3.2A

SPECIFICATIONS

	MODEL	FDA75F-24	
INPUT	VOLTAGE	[VAC] *2 180 - 528 1 φ (Refer to "Derating" and Instruction Manual 1.1) [VDC] *3 255 - 746	
	CURRENT[A]	ACIN 200V 0.75typ (47 - 63Hz) ACIN 400V 0.45typ (47 - 63Hz)	
	FREQUENCY[Hz]	50 / 60 (47 - 440)	
	EFFICIENCY[%]	ACIN 200V 86typ ACIN 400V 87typ	
	INRUSH CURRENT[A]	ACIN 200V 25typ (Io=100%) at cold start ACIN 400V 50typ (Io=100%) at cold start	
	LEAKAGE CURRENT[mA]	0.75max (ACIN 480V 60Hz, Io=100%, According to IEC62368-1)	
	OUTPUT	VOLTAGE[V]	24
		CURRENT[A]	3.2
LINE REGULATION[mV]		*4 96max	
LOAD REGULATION[mV]		*4 150max	
RIPPLE[mVp-p]		0 to +50°C 240max -20 to 0°C 320max	
RIPPLE NOISE[mVp-p]		0 to +50°C 680max -20 to 0°C 720max	
TEMPERATURE REGULATION[mV]		-20 to +50°C 600max	
DRIFT[mV]		*6 100max	
START-UP TIME[ms]		800max	
HOLD-UP TIME[ms]		10typ (ACIN 200V, Io=100%) / 20typ (ACIN 240V, Io=100%) / 60typ (ACIN 400V, Io=100%)	
OUTPUT VOLTAGE ADJUSTMENT RANGE[V]		21.60 to 26.40	
OUTPUT VOLTAGE SETTING[V]		24.00 to 24.96	
PROTECTION CIRCUIT AND OTHERS	OVERCURRENT PROTECTION	Works over 105% of rating and recovers automatically	
	OVERVOLTAGE PROTECTION	27.60 to 33.60	
	REMOTE SENSING	Not provided	
ISOLATION	INPUT-OUTPUT	4,243VAC 1minute, Cutoff current = 10mA, 500VDC 50MΩ min (At Room Temperature)	
	INPUT-FG	2,829VAC 1minute, Cutoff current = 10mA, 500VDC 50MΩ min (At Room Temperature)	
	OUTPUT-FG	500VAC 1minute, Cutoff current = 25mA, 500VDC 50MΩ min (At Room Temperature)	
ENVIRONMENT	OPERATING TEMP., HUMID. AND ALTITUDE *2	-20 to +70°C, 20 - 90%RH (Non condensing) 5,000m (16,500feet) max	
	STORAGE TEMP., HUMID. AND ALTITUDE	-20 to +75°C, 20 - 90%RH (Non condensing) 5,000m (16,500feet) max	
	VIBRATION	10 - 55Hz, 19.6m/s ² (2G), 3minutes period, 60minutes each along X, Y and Z axis	
	IMPACT	196.1m/s ² (20G), 11ms, once each X, Y and Z axis	
SAFETY AND NOISE REGULATIONS	AGENCY APPROVALS	UL62368-1, C-UL (equivalent to CAN/CSA-C22.2No.62368-1), EN62368-1	
	CONDUCTED NOISE	Complies with CISPR11-A, CISPR32-A, EN55011-A, EN55032-A, FCC Part15-A, FCC Part18-A, VCCI-A	
	HARMONIC ATTENUATOR *7	Complies with IEC61000-3-2 (Class A) (No built-in power factor correction)	
OTHERS	CASE SIZE/WEIGHT	50 X 125 X 124mm [1.97 X 4.92 X 4.88 inches] (without terminal block) (W X H X D) / 550g max	
	COOLING METHOD *2	Convection (Refer to "Derating")	

*1 The listed options may affect the published standard specifications. Please contact us for detailed product specifications.
 *2 Derating is required.
 *3 Safety agency approvals are not applicable for DC input.
 *4 At low load conditions, the burst mode operation will start. To check load regulation, you will need to measure the characteristics at average mode with instruments.
 *5 This is the value that measured on measuring board with capacitor of 22 μF and 0.1 μF at 150mm from output terminal. Measured by 20MHz oscilloscope or Ripple-Noise meter (Equivalent to KEISOKU-GIKEN:RM104). Ripple and ripple noise spec is change at Io=0 to 15% by burst operation.
 *6 Drift is the change in DC output for an eight hours period after a half-hour warm-up at 25°C.
 *7 Please contact us about another class. When two or more units are operating it may not comply with the IEC61000-3-2. Please contact us for details.
 * Do not use the power supply in overcurrent conditions or in unspecified input voltage ranges. Otherwise the internal components may be damaged.
 * Parallel operation is not possible.
 * Sound noise may be generated by power supply in case of pulse load.

Block diagram

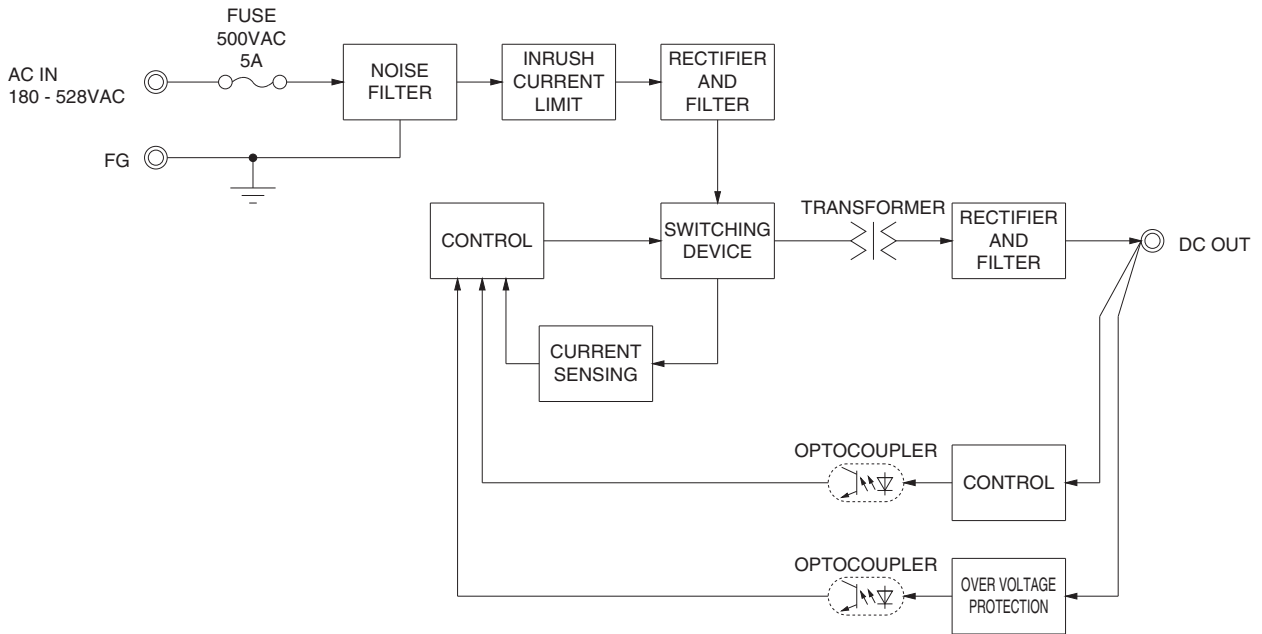

External view

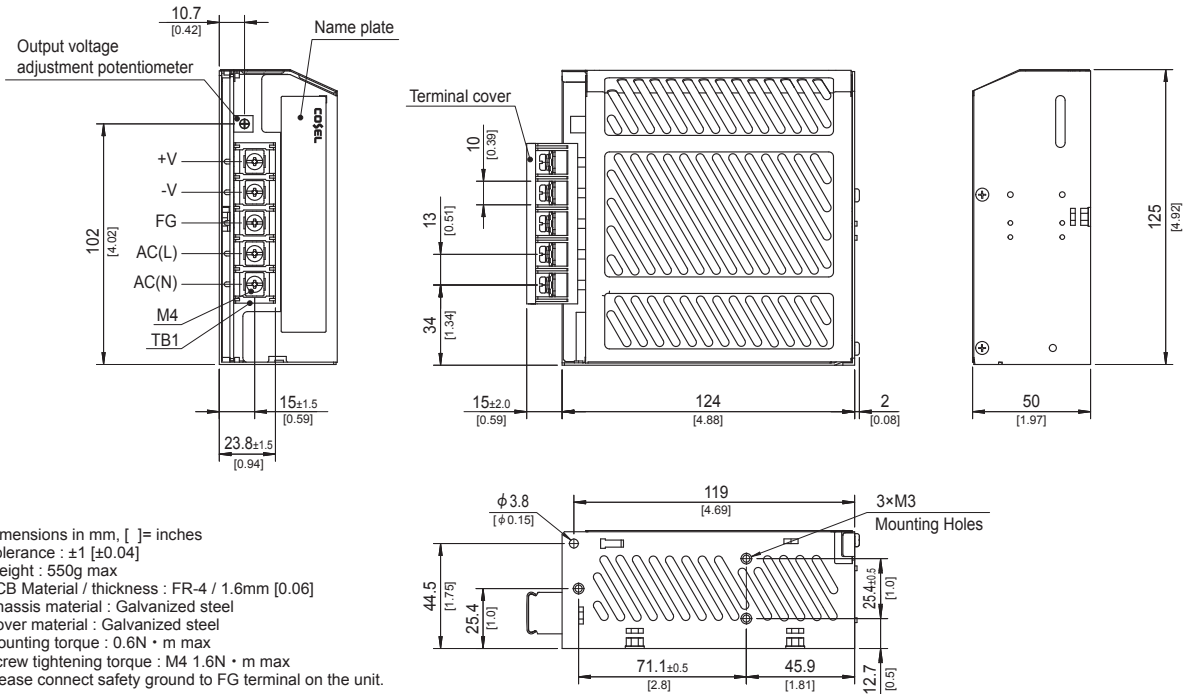

FDA150F

① **FD** ② **A** ③ **150** ④ **F** ⑤ **-□** ⑥ **-□**



- ① Series name
- ② Single output
- ③ Output wattage
- ④ Full range input
- ⑤ Output voltage
- ⑥ Optional *1
C: with Coating
N1: with DIN rail
L: with operation LED

For option details, refer to Instruction Manual 5.1.

MODEL	FDA150F-24
MAX OUTPUT WATTAGE[W]	*2 151.2
DC OUTPUT	*2 24V 6.3A

SPECIFICATIONS

MODEL		FDA150F-24	
INPUT	VOLTAGE	[VAC] *2 180 - 528 1 φ (Refer to "Derating" and Instruction Manual 1.1) [VDC] *3 255 - 530	
	CURRENT[A]	ACIN 200V 0.90typ ACIN 400V 0.50typ	
	FREQUENCY[Hz]	50 / 60 (47 - 63)	
	EFFICIENCY[%]	ACIN 200V 86typ ACIN 400V 87typ	
	POWER FACTOR (lo=100%)	ACIN 200V 0.98typ ACIN 400V 0.90typ	
	INRUSH CURRENT[A]	ACIN 200V 25typ (lo=100%) at cold start ACIN 400V 50typ (lo=100%) at cold start	
	LEAKAGE CURRENT[ma]	0.75max (ACIN 480V 60Hz, lo=100%, According to IEC62368-1)	
	OUTPUT	VOLTAGE[V]	24
		CURRENT[A]	6.3
		LINE REGULATION[mV]	*4 96max
LOAD REGULATION[mV]		*4 150max	
RIPPLE[mVp-p]		0 to +50°C 240max *5 -20 to 0°C 320max	
RIPPLE NOISE[mVp-p]		0 to +50°C 680max *5 -20 to 0°C 720max	
TEMPERATURE REGULATION[mV]		-20 to +50°C 600max	
DRIFT[mV]		*6 100max	
START-UP TIME[ms]		800max	
HOLD-UP TIME[ms]		30typ (ACIN 200V, lo=100%)	
OUTPUT VOLTAGE ADJUSTMENT RANGE[V]		21.60 to 26.40	
OUTPUT VOLTAGE SETTING[V]	24.00 to 24.96		
PROTECTION CIRCUIT AND OTHERS	OVERCURRENT PROTECTION	Works over 105% of rating and recovers automatically	
	OVERVOLTAGE PROTECTION	27.60 to 33.60	
	REMOTE SENSING	Not provided	
ISOLATION	INPUT-OUTPUT	4,243VAC 1minute, Cutoff current = 10mA, 500VDC 50MΩ min (At Room Temperature)	
	INPUT-FG	2,829VAC 1minute, Cutoff current = 10mA, 500VDC 50MΩ min (At Room Temperature)	
	OUTPUT-FG	500VAC 1minute, Cutoff current = 25mA, 500VDC 50MΩ min (At Room Temperature)	
ENVIRONMENT	OPERATING TEMP., HUMID. AND ALTITUDE *2	-20 to +70°C, 20 - 90%RH (Non condensing) 5,000m (16,500feet) max	
	STORAGE TEMP., HUMID. AND ALTITUDE	-20 to +75°C, 20 - 90%RH (Non condensing) 5,000m (16,500feet) max	
	VIBRATION	10 - 55Hz, 19.6m/s ² (2G), 3minutes period, 60minutes each along X, Y and Z axis	
	IMPACT	196.1m/s ² (20G), 11ms, once each X, Y and Z axis	
SAFETY AND NOISE REGULATIONS	AGENCY APPROVALS	UL62368-1, C-UL (equivalent to CAN/CSA-C22.2No.62368-1), EN62368-1	
	CONDUCTED NOISE	Complies with CISPR11-A, CISPR32-A, EN55011-A, EN55032-A, FCC Part15-A, FCC Part18-A, VCCI-A	
OTHERS	HARMONIC ATTENUATOR *7	Complies with IEC61000-3-2 (Class A)	
	CASE SIZE/WEIGHT	65 X 125 X 124mm [2.56 X 4.92 X 4.88 inches] (without terminal block) (W X H X D) / 800g max	
	COOLING METHOD *2	Convection (Refer to "Derating")	

*1 The listed options may affect the published standard specifications. Please contact us for detailed product specifications.
 *2 Derating is required.
 *3 Safety agency approvals are not applicable for DC input.
 *4 At low load conditions, the burst mode operation will start. To check load regulation, you will need to measure the characteristics at average mode with instruments.
 *5 This is the value that measured on measuring board with capacitor of 22 μF and 0.1 μF at 150mm from output terminal. Measured by 20MHz oscilloscope or Ripple-Noise meter (Equivalent to KEISOKU-GIKEN:RM104). Ripple and ripple noise spec is change at lo=0 to 15% by burst operation.
 *6 Drift is the change in DC output for an eight hours period after a half-hour warm-up at 25°C.
 *7 Please contact us about another class. When two or more units are operating it may not comply with the IEC61000-3-2. Please contact us for details.
 * Do not use the power supply in overcurrent conditions or in unspecified input voltage ranges. Otherwise the internal components may be damaged.
 * Parallel operation is not possible.
 * Sound noise may be generated by power supply in case of pulse load.

Block diagram

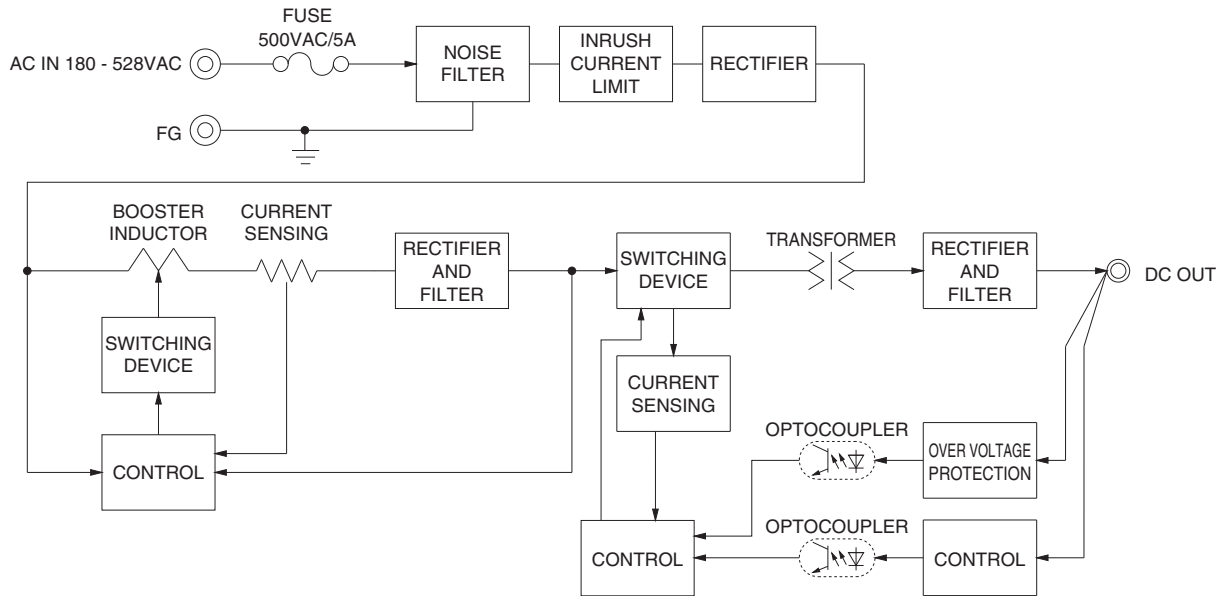

External view

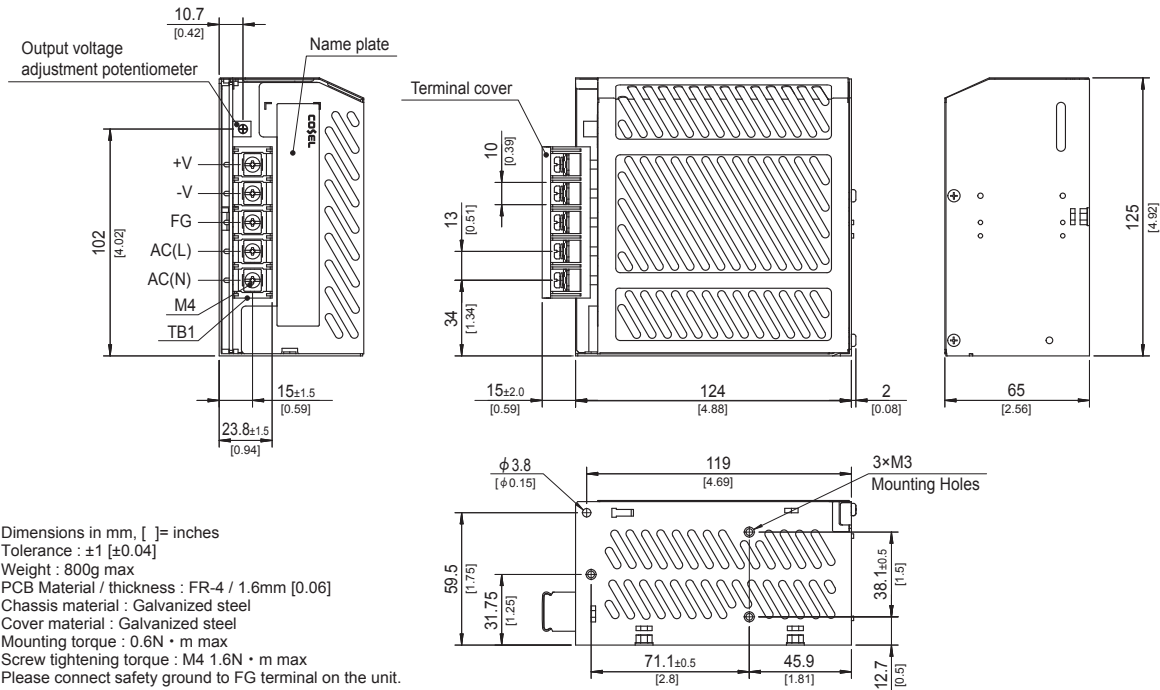

- * Dimensions in mm, []= inches
- * Tolerance : ±1 [±0.04]
- * Weight : 800g max
- * PCB Material / thickness : FR-4 / 1.6mm [0.06]
- * Chassis material : Galvanized steel
- * Cover material : Galvanized steel
- * Mounting torque : 0.6N · m max
- * Screw tightening torque : M4 1.6N · m max
- * Please connect safety ground to FG terminal on the unit.

FDA200F

① **FD** ② **A** ③ **200** ④ **F** ⑤ **-□** ⑥ **-□**



- ① Series name
- ② Single output
- ③ Output wattage
- ④ Full range input
- ⑤ Output voltage
- ⑥ Optional *1
 C: with Coating
 N1: with DIN rail
 L: with operation LED

For option details, refer to Instruction Manual 5.1.

MODEL	FDA200F-24
MAX OUTPUT WATTAGE[W]	*2 201.6
DC OUTPUT	*2 24V 8.4A

SPECIFICATIONS

MODEL		FDA200F-24	
INPUT	VOLTAGE	[VAC] *2 180 - 528 1 φ (Refer to "Derating" and Instruction Manual 1.1) [VDC] *3 255 - 530	
	CURRENT[A]	ACIN 200V 1.20typ ACIN 400V 0.60typ	
	FREQUENCY[Hz]	50 / 60 (47 - 63)	
	EFFICIENCY[%]	ACIN 200V 87typ ACIN 400V 88typ	
	POWER FACTOR (Io=100%)	ACIN 200V 0.98typ ACIN 400V 0.93typ	
	INRUSH CURRENT[A]	ACIN 200V 25typ (Io=100%) at cold start ACIN 400V 50typ (Io=100%) at cold start	
	LEAKAGE CURRENT[ma]	0.75max (ACIN 480V 60Hz, Io=100%, According to IEC62368-1)	
	OUTPUT	VOLTAGE[V]	24
		CURRENT[A]	8.4
		LINE REGULATION[mV]	*4 96max
LOAD REGULATION[mV]		*4 150max	
RIPPLE[mVp-p]		0 to +40°C 240max *5 -20 to 0°C 320max	
RIPPLE NOISE[mVp-p]		0 to +40°C 680max *5 -20 to 0°C 720max	
TEMPERATURE REGULATION[mV]		-20 to +40°C 600max	
DRIFT[mV]		*6 100max	
START-UP TIME[ms]		800max	
HOLD-UP TIME[ms]		20typ (ACIN 200V, Io=100%)	
OUTPUT VOLTAGE ADJUSTMENT RANGE[V]		21.60 to 26.40	
OUTPUT VOLTAGE SETTING[V]		24.00 to 24.96	
PROTECTION CIRCUIT AND OTHERS	OVERCURRENT PROTECTION	Works over 105% of rating and recovers automatically	
	OVERVOLTAGE PROTECTION	27.60 to 33.60	
	REMOTE SENSING	Not provided	
ISOLATION	INPUT-OUTPUT	4,243VAC 1minute, Cutoff current = 10mA, 500VDC 50MΩ min (At Room Temperature)	
	INPUT-FG	2,829VAC 1minute, Cutoff current = 10mA, 500VDC 50MΩ min (At Room Temperature)	
	OUTPUT-FG	500VAC 1minute, Cutoff current = 25mA, 500VDC 50MΩ min (At Room Temperature)	
ENVIRONMENT	OPERATING TEMP., HUMID. AND ALTITUDE *2	-20 to +70°C, 20 - 90%RH (Non condensing) 5,000m (16,500feet) max	
	STORAGE TEMP., HUMID. AND ALTITUDE	-20 to +75°C, 20 - 90%RH (Non condensing) 5,000m (16,500feet) max	
	VIBRATION	10 - 55Hz, 19.6m/s ² (2G), 3minutes period, 60minutes each along X, Y and Z axis	
	IMPACT	196.1m/s ² (20G), 11ms, once each X, Y and Z axis	
SAFETY AND NOISE REGULATIONS	AGENCY APPROVALS	UL62368-1, C-UL (equivalent to CAN/CSA-C22.2No.62368-1), EN62368-1	
	CONDUCTED NOISE	Complies with CISPR11-A, CISPR32-A, EN55011-A, EN55032-A, FCC Part15-A, FCC Part18-A, VCCI-A	
OTHERS	HARMONIC ATTENUATOR *7	Complies with IEC61000-3-2 (Class A)	
	CASE SIZE/WEIGHT	65 X 125 X 124mm [2.56 X 4.92 X 4.88 inches] (without terminal block) (W X H X D) / 800g max	
	COOLING METHOD *2	Convection (Refer to "Derating")	

*1 The listed options may affect the published standard specifications. Please contact us for detailed product specifications.
 *2 Derating is required.
 *3 Safety agency approvals are not applicable for DC input.
 *4 At low load conditions, the burst mode operation will start. To check load regulation, you will need to measure the characteristics at average mode with instruments.
 *5 This is the value that measured on measuring board with capacitor of 22 μF and 0.1 μF at 150mm from output terminal. Measured by 20MHz oscilloscope or Ripple-Noise meter (Equivalent to KEISOKU-GIKEN:RM104). Ripple and ripple noise spec is change at Io=0 to 15% by burst operation.
 *6 Drift is the change in DC output for an eight hours period after a half-hour warm-up at 25°C.
 *7 Please contact us about another class. When two or more units are operating it may not comply with the IEC61000-3-2. Please contact us for details.
 * Do not use the power supply in overcurrent conditions or in unspecified input voltage ranges. Otherwise the internal components may be damaged.
 * Parallel operation is not possible.
 * Sound noise may be generated by power supply in case of pulse load.

Block diagram

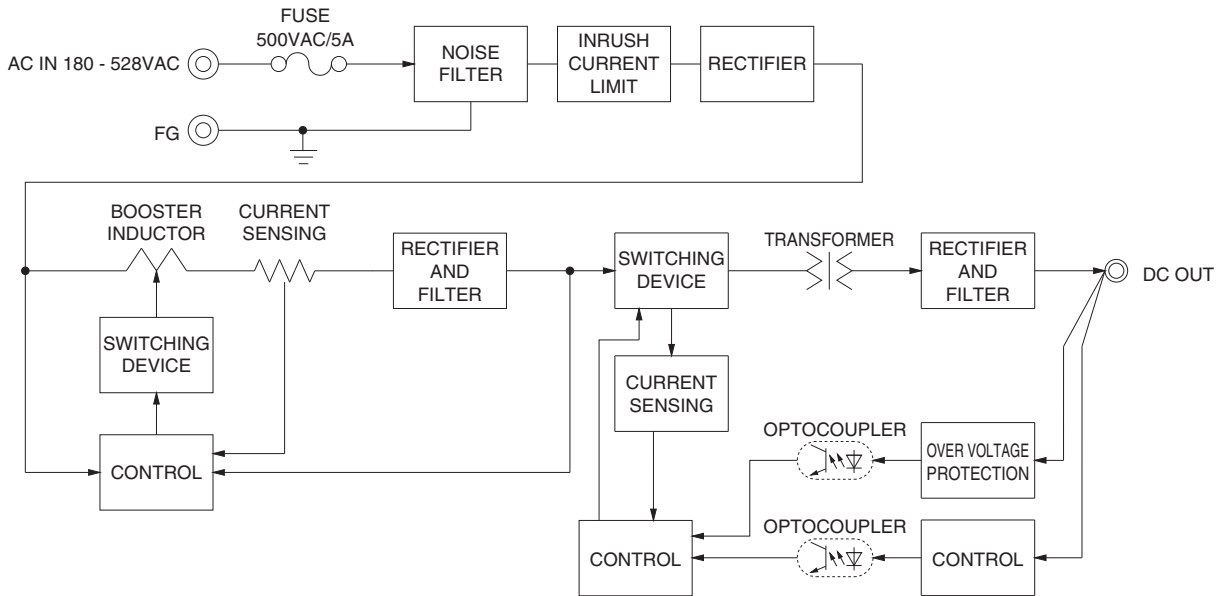

External view

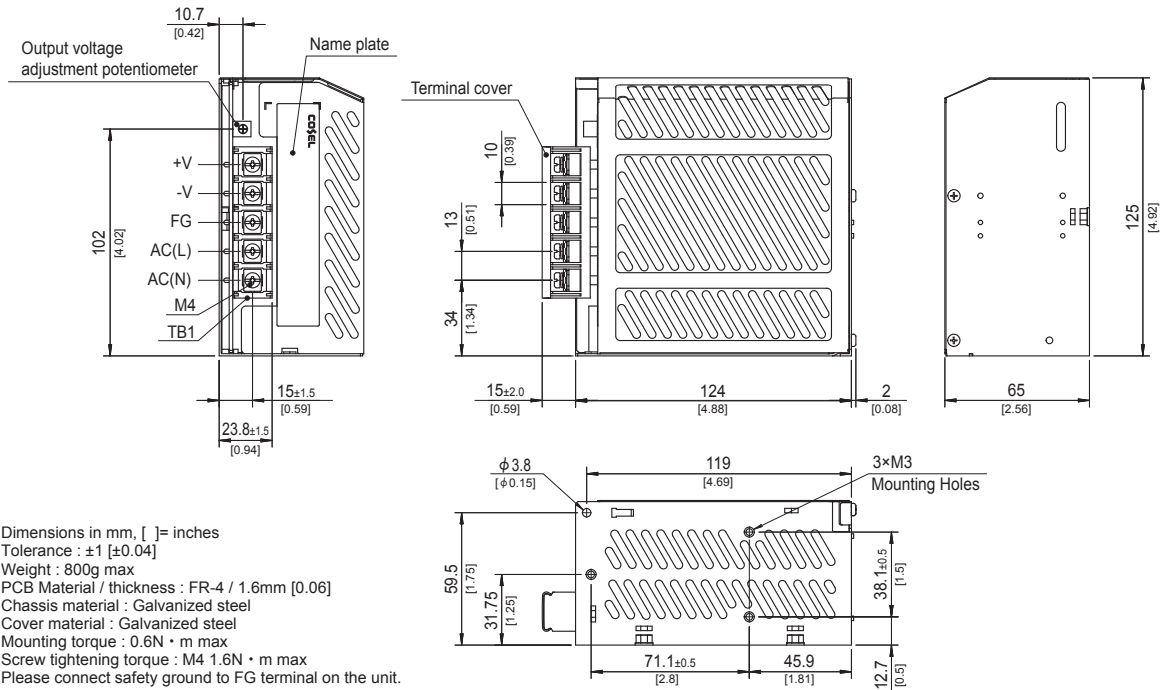

- * Dimensions in mm, []= inches
- * Tolerance : ±1 [±0.04]
- * Weight : 800g max
- * PCB Material / thickness : FR-4 / 1.6mm [0.06]
- * Chassis material : Galvanized steel
- * Cover material : Galvanized steel
- * Mounting torque : 0.6N · m max
- * Screw tightening torque : M4 1.6N · m max
- * Please connect safety ground to FG terminal on the unit.

Assembling and Installation Method

Installation method

■ Do not insert a screw more than 6mm from the outside of a power supply to keep enough insulation distance between the screw and internal components.

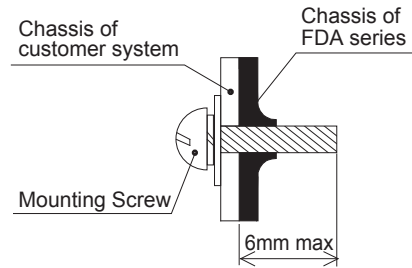

- If you use two or more power supplies side by side, please keep a sufficient distance between them to allow enough air ventilation.
- Ambient temperature around each power supply should not exceed the temperature range shown in “Derating”.

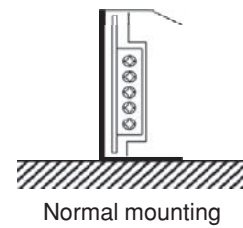

Derating

● Derating curve for input voltage

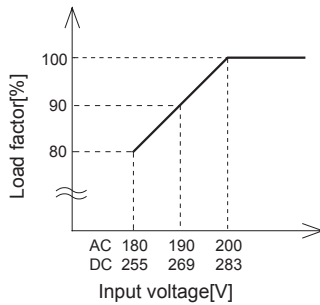

● FDA50F/75F

Ambient temperature derating curve at rated input

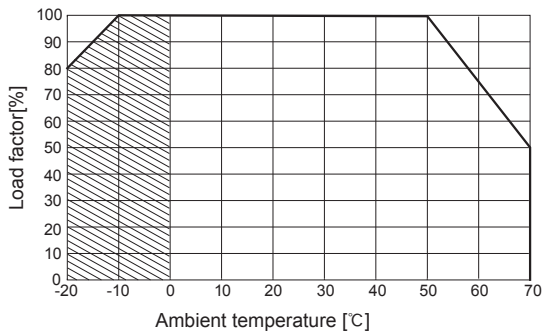

Derating

- **FDA150F**
Ambient temperature derating curve at rated input

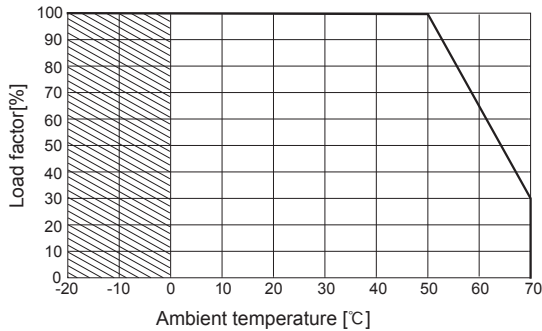

- **FDA200F**
Ambient temperature derating curve at rated input

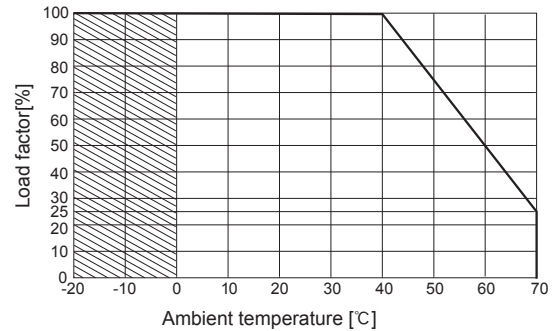

- In the hatched area, the specification of Ripple, Ripple Noise is different from other area.
- The ambient temperature should be measured 5 to 10 cm away from the power supply so that it won't be influenced by the heat from the power supply.
- Please contact us for more information about operating ambient temperature.

Instruction Manuals

- ◆ Please read the "Instruction Manual" and "Before using our product" before you use our product.

Basic Characteristics Data

Model	Circuit method	Switching frequency [kHz] *1 *2	Input current [A] *3	Inrush current protection	PCB/Pattern			Series/Parallel operation availability	
					Material	Single sided	Double	Series operation	Parallel operation
FDA50F	Flyback converter	20 to 125	0.50	Thermistor	FR-4	-	Yes	Yes	No
FDA75F	Flyback converter	20 to 125	0.75	Thermistor	FR-4	-	Yes	Yes	No
FDA150F	Active filter	65	0.90	Thermistor	FR-4	-	Yes	Yes	No
	Flyback converter	20 to 125							
FDA200F	Active filter	65	1.20	Thermistor	FR-4	-	Yes	Yes	No
	Flyback converter	20 to 125							

*1 The value changes depending on input and load.
 *2 At light load, burst operation is performed to reduce input power. The switching frequency is changed by using condition. Please contact us for more details.
 *3 The value of input current is at ACIN 200V and rated load.