

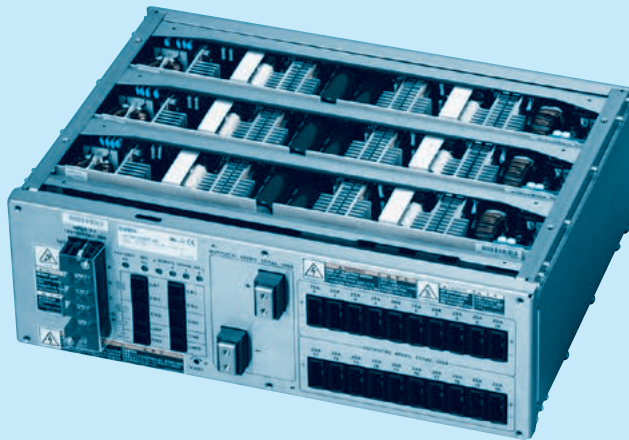

SC-series

DC48V Front end power supply



SCHA10000T

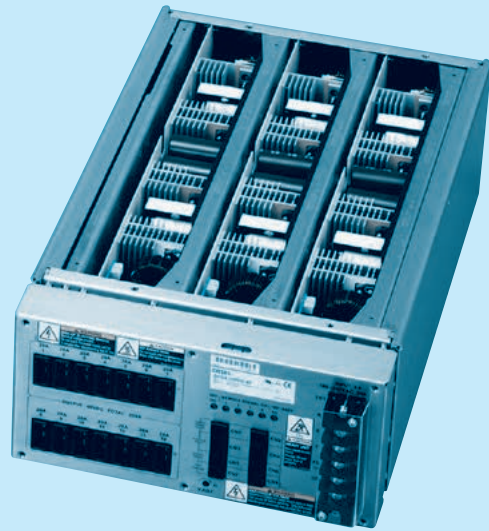

SCDA10000T

Feature

- High power, AC-DC front end power supply
- Three-phase input(AC160 - 264V 3 ϕ)
- High efficiency (90%), High power factor (0.99)
- Harmonic attenuator (Complies with IEC61000-3-12)
- Complies with SEMI F47
- Wide output voltage adjustable range approximately 0 to 52.8V (Optional)
- Constant current regulation provided with additional external components (Optional)
- Parallel operation and Parallel redundancy operation (SCHA10000T)
- System ON / OFF (Remote ON / OFF)
- Alarms
- Output Voltage Monitor
- Parallel Control (Start in / out)
- Remote Signal ON / OFF

Safety agency approvals

UL60950-1, C-UL, EN62368-1

3-year warranty

CE marking

Low Voltage Directive
RoHS Directive

UKCA marking

Electrical Equipment Safety Regulations
RoHS Regulations

EMI

Complies with EN55011 Group1-A, EN55022-A, CISPR22-A, FCC Part15 classA

EMS Compliance : EN61204-3, EN61000-6-2

EN61000-4-2
EN61000-4-3
EN61000-4-4
EN61000-4-5
EN61000-4-6
EN61000-4-8
EN61000-4-11

SCHA 10000T/SCDA 10000T

SC H A 10000 T -48 -□

① ② ③ ④ ⑤ ⑥ ⑦

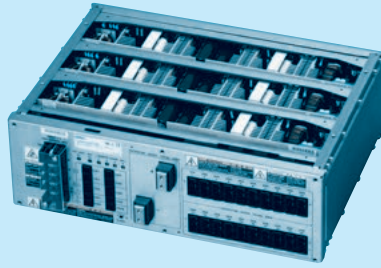

SCHA10000T



SCDA10000T

Example recommended EMI/EMC filter
Filter TAC-50-223

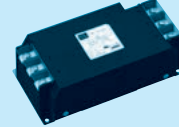

*A higher current rating EMI/EMC filter may be recommended in view of the other devices that could be connected in parallel with the power supply.

- ① Series name
- ② External form
H:Wide front interface
D:Compact front interface
- ③ Single output
- ④ Output wattage
- ⑤ Three-phase input
- ⑥ Output voltage
- ⑦ Optional

*Make sure necessary tests will be carried out on your end equipment with the power supply installed in accordance with any required EMC/EMI regulations.

SPECIFICATIONS

	MODEL	SCHA10000T-48	SCDA10000T-48	
INPUT	VOLTAGE[V]	AC160 - 264 3 φ		
	CURRENT[A]	ACIN200V	35typ	
	FREQUENCY[Hz]	50/60 (47 - 63)		
	EFFICIENCY[%]	ACIN200-240V	90typ	
	POWER FACTOR	ACIN200-240V	0.99typ (Io=100%)	
	INRUSH CURRENT[A]	ACIN240V *1	60typ / 80typ (Primary inrush current /Secondary inrush current) (More than 3 sec. to re-start)	
	LEAKAGE CURRENT[mA]	5.0max (ACIN 240V 60Hz, Io=0 - 100%, According to IEC62368-1)		
OUTPUT	VOLTAGE[V]	48		
	CURRENT[A]	208		
	WATTAGE[W]	9,984		
	LINE REGULATION[mV]	192max		
	LOAD REGULATION[mV]	720max		
	RIPPLE[mVp-p]	0 to +50°C *2	150max	
	RIPPLE NOISE[mVp-p]	0 to +50°C *2	200max (BW:500MHz)	
	TEMPERATURE REGULATION[mV]	0 to +50°C	240max	
	DRIFT[mV]	*3	192max	
	START-UP TIME[ms]	*6	750max (ACIN 200V, Io=100%)	
	HOLD-UP TIME[ms]	20typ (ACIN200V, Io=100%)		
OUTPUT VOLTAGE ADJUSTMENT RANGE[V]	43.2 - 52.8			
OUTPUT VOLTAGE SETTING[V]	47.0 - 49.0			
PROTECTION CIRCUIT AND OTHERS	OVERCURRENT PROTECTION	Activate over 105% - 120% of rated current and recovers automatically. (Shut down if low-voltage protection activated)		
	OVERVOLTAGE PROTECTION[V]	*4	56.0 - 59.0 (shut down)	
	LOW-VOLTAGE PROTECTION[V]	*4	28.8 - 33.6 (shut down)	
	OPERATING INDICATION	LED : Green (48VDC output), White (AC IN)		
	ALARM OUTPUT	Detecting low input voltage, detecting open phase, detecting low output voltage		
REMOTE ON/OFF (SYSTEM ON/OFF)	Provided			
ISOLATION	(INPUT) - (OUTPUT - SYSTEM ON/OFF - REMOTE SIGNAL ON/OFF - ALARM)	AC3,000V 1minute, Cutoff current = 100mA, DC2,200V 1minute, Cutoff current = 1mA (At Room Temperature) DC500V 50MΩ min (At Room Temperature)		
	(INPUT) - (FG)	AC2,000V 1minute, Cutoff current = 100mA, DC2,200V 1minute, Cutoff current = 1mA (At Room Temperature) DC500V 50MΩ min (At Room Temperature)		
	(OUTPUT - SYSTEM ON/OFF - REMOTE SIGNAL ON/OFF - ALARM) - (FG)	AC500V 1minute, Cutoff current = 100mA, DC500V 50MΩ min (At Room Temperature)		
	(OUTPUT) - (SYSTEM ON/OFF - REMOTE SIGNAL ON/OFF - ALARM)	AC100V 1minute, Cutoff current = 50mA, DC100V 10MΩ min (At Room Temperature)		
ENVIRONMENT	OPERATING TEMP., HUMID. AND ALTITUDE	0 to +50°C, 20 - 85%RH (Non condensing), 3,000m(10,000feet) max (Refer to Cooling method)		
	STORAGE TEMP., HUMID. AND ALTITUDE	-25 to +85°C, 20 - 90%RH (Non condensing), 9,000m(30,000feet) max		
	VIBRATION	10 - 55Hz, 19.6m/s ² (2G), 3minutes period, 30 minutes each along X, Y and Z axis		
	IMPACT	196.1m/s ² (20G), 11ms, once each along X, Y and Z axis		
SAFETY AND NOISE REGULATIONS	AGENCY APPROVALS	UL60950-1, C-UL (CSA60950-1), EN62368-1 complies		
	CONDUCTED NOISE	Complies with EN55011 Group1-A, EN55022-A, CISPR22-A, FCC part15 classA, additional EMI/EMC Filter required for meeting class B		
	HARMONIC ATTENUATOR	Complies with IEC61000-3-12		
OTHERS	CASE SIZE/WEIGHT *5	459 X 150 X 320mm [18.07 X 5.91 X 12.6 inches] (W X H X D)/23kg max	310.5 X 150 X 510mm [12.22 X 5.91 X 20.08 inches] (W X H X D)/20kg max	
	COOLING METHOD	Forced cooling (require external fan)		

*1 The current of input surge to a built-in noise filter (0.2ms or less) is excluded.

*2 Measured by 500MHz oscilloscope.

*3 Drift is the change in DC output for an eight hour period after a half-hour warm-up at 25°C, with the input voltage held constant at the rated input/output.

*4 To recover output voltage, recycle input voltage after 3 or more seconds.

*5 Case size contains neither the terminal blocks, connector and screw nor.

*6 When input voltage recycling is needed for output recovery, AC power shall be removed and cycled after 3 seconds to reset the protection circuit.

Please contact us when it's necessary to restart the power supply in less than 3 seconds.

SCHA/SCDA1000T Block diagram

● SCHA/SCDA1000T Block diagram

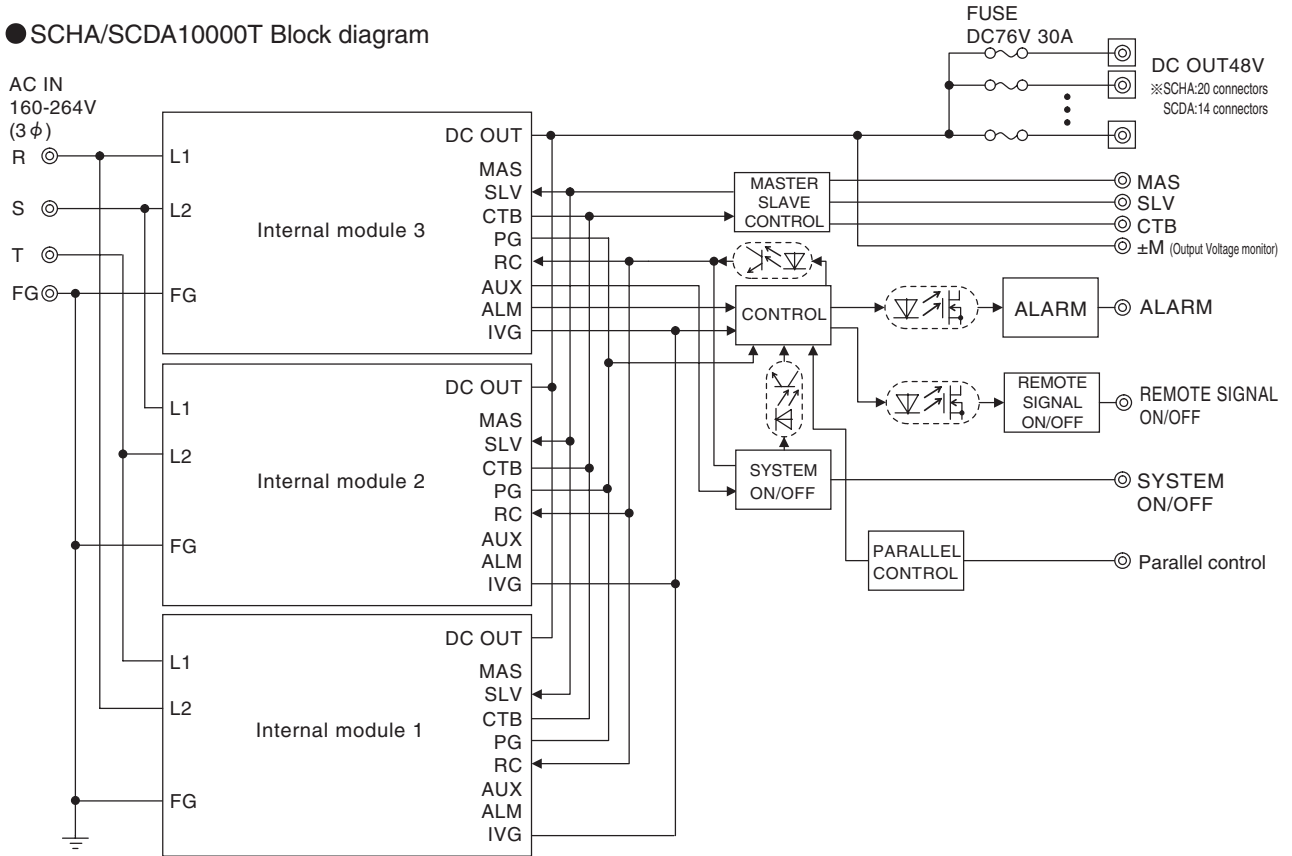

● Internal module Block diagram

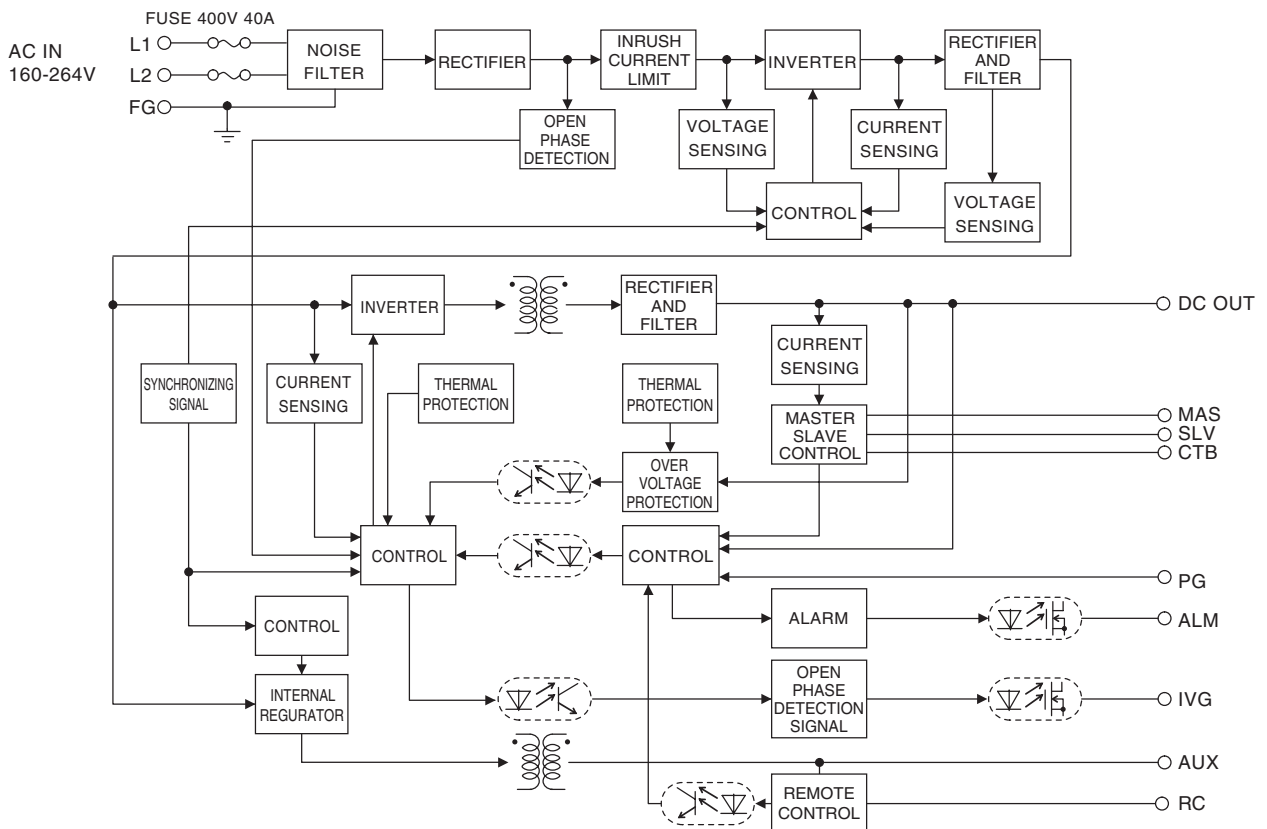

SCHA1000T external view

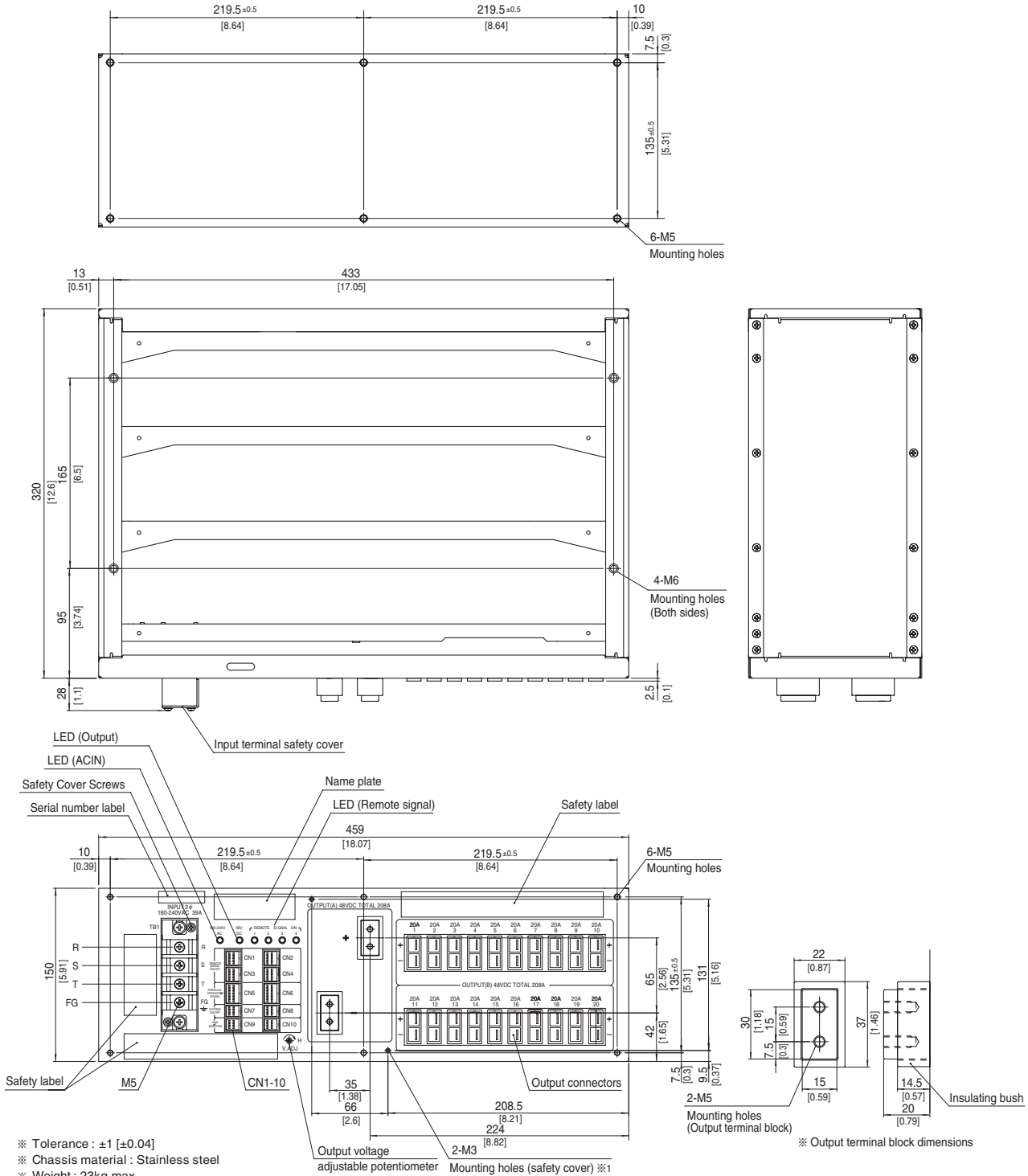

- ※ Tolerance : ±1 [±0.04]
- ※ Chassis material : Stainless steel
- ※ Weight : 23kg max
- ※ PCB Material/thickness : FR-4 / 1.6mm [0.04]
- ※ Dimensions in mm, []=inches
- ※ Screw tightening torque : M5 Mounting Hole 3.0N · m (30.7kgf · cm) max
- : M6 Mounting Hole 5.4N · m (55.2kgf · cm) max
- : M5 Mounting Hole(Output terminal block) 2.7N · m (27.6kgf · cm) max
- : M5 Input terminal 3.0N · m (30.7kgf · cm) max
- : M3 Mounting Hole (safety cover) 0.6N · m (6.2kgf · cm) max
- : M3 Input terminal safety cover 0.6N · m (6.2kgf · cm) max

- ※ LED (ACIN) : White with AC input
- ※ LED (Output) : Green with 48VDC output
- ※ LED (Remote signal) : Green (Indicates Remote signal status)

※ 1 Bus-bar safety cover, optional accessory.

SCDA10000T external view

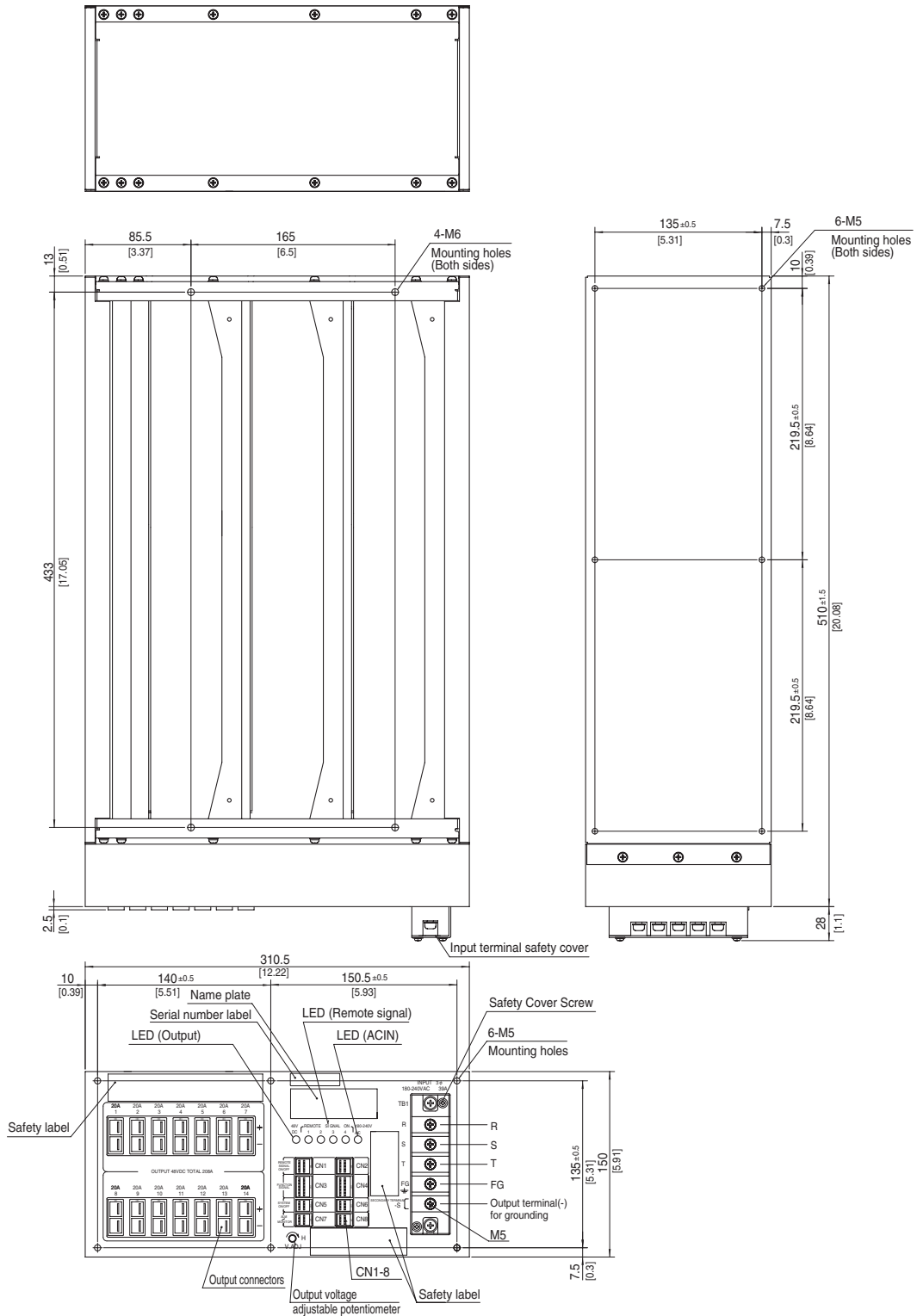

※ Tolerance : ±1 [±0.04]

※ Chassis material : Stainless steel

※ Weight : 20kg max

※ PCB Material/thickness : FR-4 / 1.6mm [0.04]

※ Dimensions in mm, []=inches

※ Screw tightening torque : M5 Mounting Hole 3.0N · m (30.7kgf · cm) max

: M6 Mounting Hole 5.4N · m (55.2kgf · cm) max

: M5 Input terminal 3.0N · m (30.7kgf · cm) max

: M3 Input terminal safety cover 0.6N · m (6.2kgf · cm) max

※ LED (ACIN) : White with AC input

※ LED (Output) : Green with 48VDC output

※ LED (Remote signal) : Green (Indicates Remote signal status)

※ Output terminal(-) for grounding

-Output terminal(-) is internally connected to DC48V Output (-).

-Output terminal(-) : For grounding to stabilize secondary output by connecting to system ground (earth).

-Can not draw current through output terminal(-) for grounding.

SCHA1000T external view (front panel)

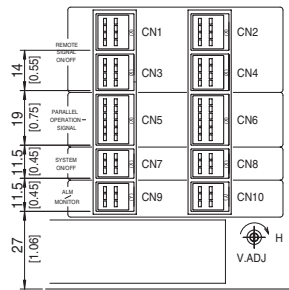
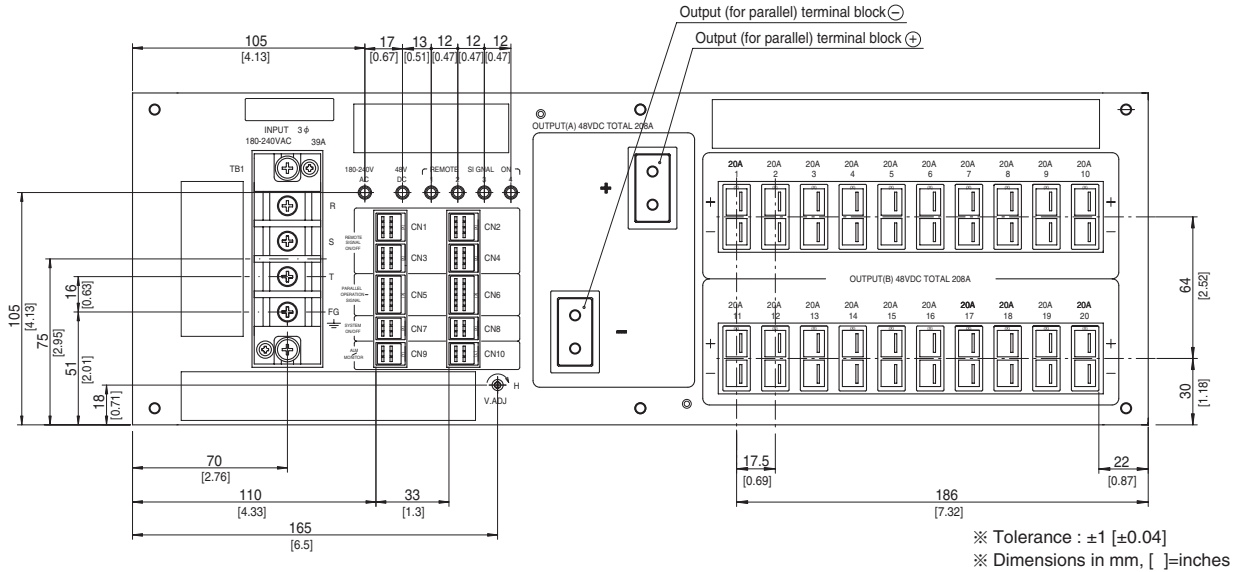

CN1-10 location dimensions

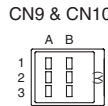
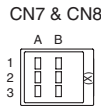
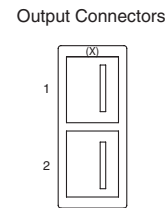
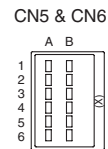
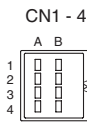

Connector pin numbers

SCHA1000T Functions & Connectors

Connector	Housing	Mfr.	Pin No.	Function
Output connector	1-353080-2	1-179958-2	1	Output (+)
			2	Output (-)
CN1-CN4	1318125-1	1-1318119-4	1A	Remote signal ON/OFF 1+
			1B	Remote signal ON/OFF 1-
			2A	Remote signal ON/OFF 2+
			2B	Remote signal ON/OFF 2-
			3A	Remote signal ON/OFF 3+
			3B	Remote signal ON/OFF 3-
			4A	Remote signal ON/OFF 4+
			4B	Remote signal ON/OFF 4-
CN5 & CN6	1318126-1	1-1318118-6	1A,1B	MAS: Master
			2A,2B	SLV: Slave
			3A,3B	CTB: Current balance
			4A,4B	PCNT: Parallel control
			5A,5B	COM:GND
			6A,6B	N.C.
CN7 & CN8	1318124-1	1-1318119-3	1A,1B	System ON/OFF +
			3A,3B	System ON/OFF -
			2A,2B	N.C.
CN9 & CN10	1318124-2	2-1318119-3	1A,1B	Alarm +
			3A,3B	Alarm -
			2A	+M: Output voltage monitor+
			2B	-M: Output voltage monitor-

SCDA10000T external view (front panel)

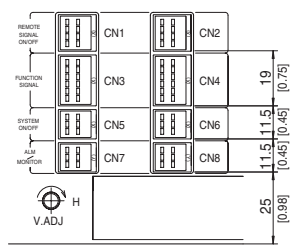
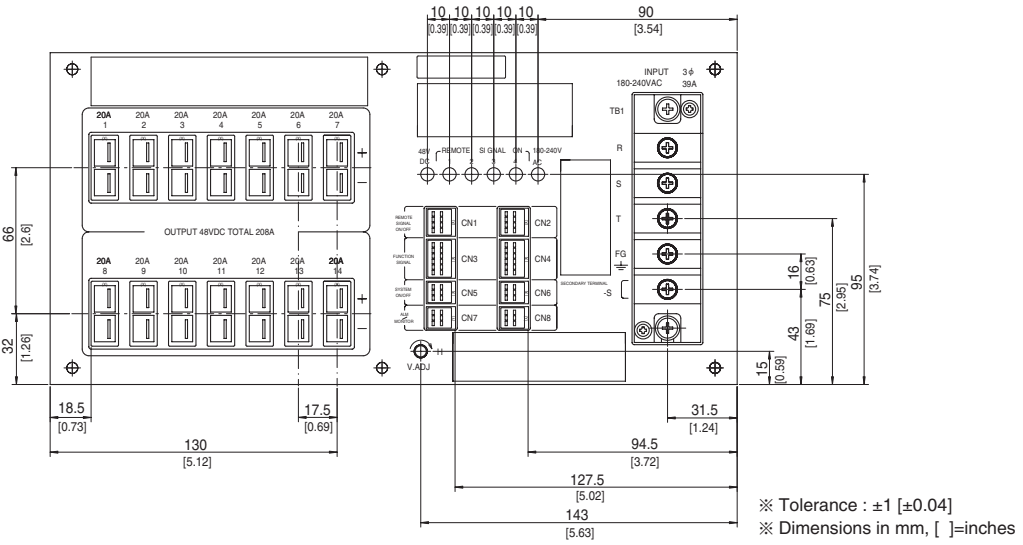

CN1-8 location dimensions

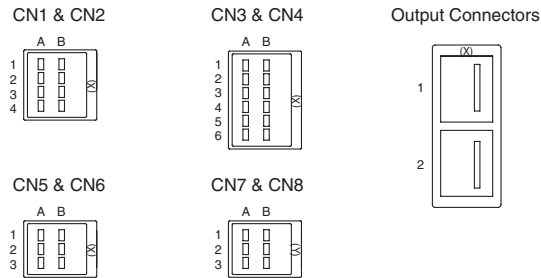

Connector pin numbers

SCDA10000T Functions & Connectors

Connector	Housing	Mfr.	Pin No.	Function	
Output connector	1-353080-2	1-179958-2	1	Output (+)	
			2	Output (-)	
CN1 & CN2	1318125-1	1-1318119-4	Tyco Electronics AMP	1A	Remote signal ON/OFF 1+
				1B	Remote signal ON/OFF 1-
				2A	Remote signal ON/OFF 2+
				2B	Remote signal ON/OFF 2-
				3A	Remote signal ON/OFF 3+
				3B	Remote signal ON/OFF 3-
				4A	Remote signal ON/OFF 4+
				4B	Remote signal ON/OFF 4-
CN3 & CN4	1318126-1	1-1318118-6	Tyco Electronics AMP	1A,1B	MAS: Master
				2A,2B	SLV: Slave
				3A,3B	CTB: Current balance
				4A,4B	PCNT: Parallel control
				5A,5B	COM:GND
				6A,6B	N.C.
CN5 & CN6	1318124-1	1-1318119-3	Tyco Electronics AMP	1A,1B	System ON/OFF +
				3A,3B	System ON/OFF -
				2A,2B	N.C.
CN7 & CN8	1318124-2	2-1318119-3	Tyco Electronics AMP	1A,1B	Alarm +
				3A,3B	Alarm -
				2A	+M: Output voltage monitor+
				2B	-M: Output voltage monitor-

Connection diagram of function connectors

● SCHA10000T

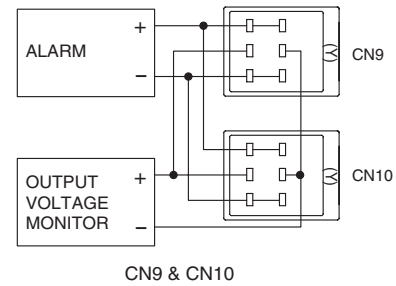
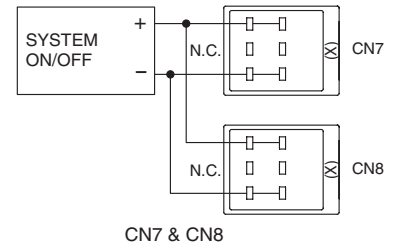
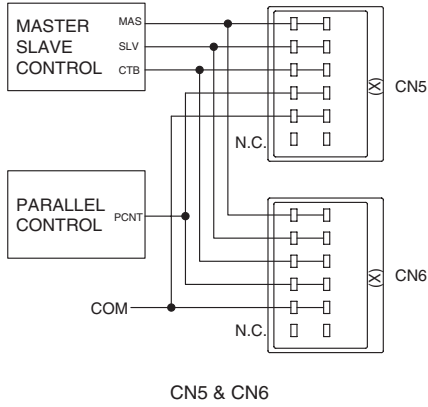
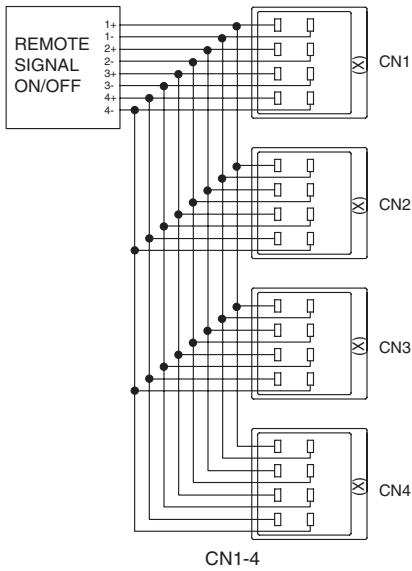

● SCDA10000T

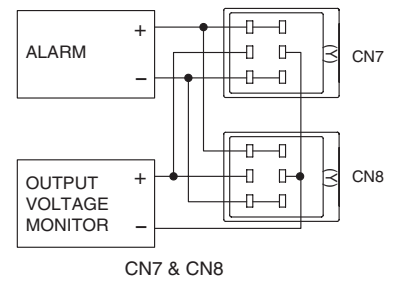
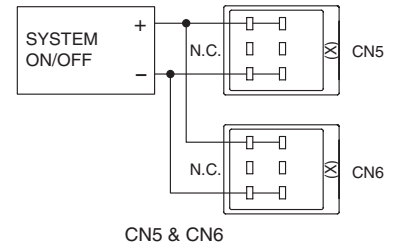
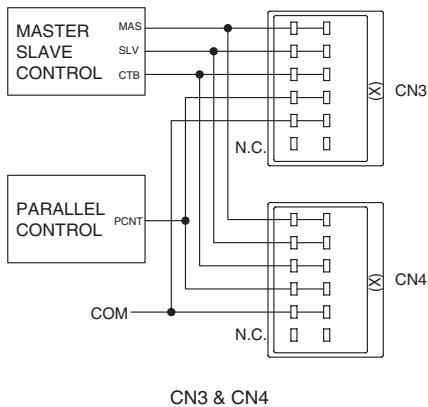
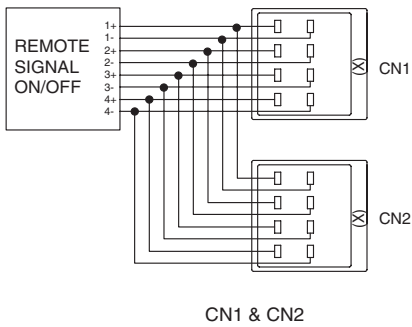

Assembling and Installation Method

Installation method

- Screw mounting has to be consider the product weight for safety fixture.
- To keep enough insulation distance between screws and internal components, length of the mounting screw should not exceed recommendation as right figure.

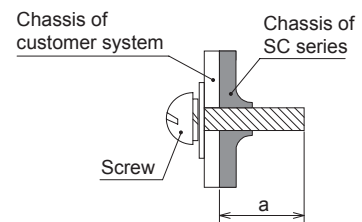

Mounting hole	Diameter	a (Max penetration length)
Chassis	M6	8mm max
	M5	7mm max
Output terminal block (SCHA10000T)	M5	10mm max
Safety cover (Bus bar) (SCHA10000T)	M3	7mm max

Assembling and Installation Method

Cooling Method

This power supply unit is designed for assuming external cooling fans. Follow instruction of cooling condition as follows.

- Built into cooling air flow line in the system (Duct structure air cooling) for uniform cooling air flow.
- Number of stacked units is up to 3, as shown in Fig① and Fig②.
- Air flow direction is either Up or Down as shown in Fig① to Fig③.
- Clearance between stacked units is $1.5\text{mm} \leq d \leq 6\text{mm}$.
- Fig① to Fig③ show the position of cooling fan unit.
- Contact us for more information if your design utilizes other cooling methods.
- Stacking 4 units or more is not allowed.

① Cooling methods for use of single unit

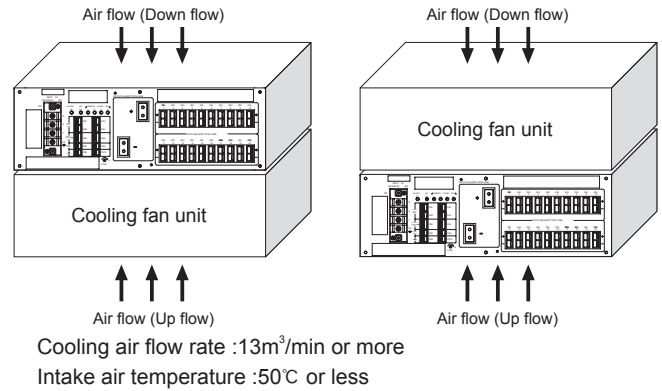

② Cooling methods for use of 2 units

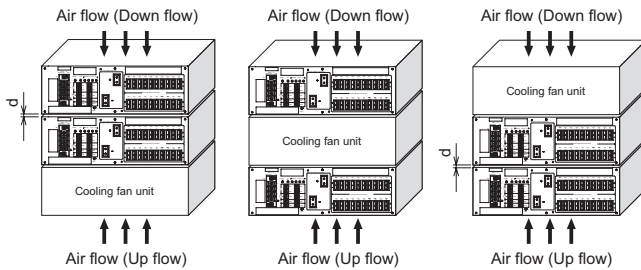

③ Cooling methods for use of 3 units

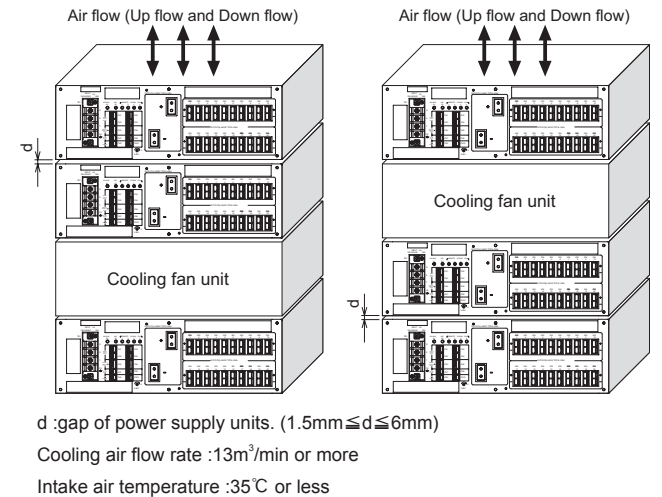

Instruction Manual

- ◆ It is necessary to read the "Instruction Manual" and "Before using our product" before you use our product.

Basic Characteristics Data

Model	Circuit method	Switching frequency [kHz]	Input current [A]	Rated input fuse	Inrush current protection circuit	PCB/Pattern		
						Material	Single sided	Double sided
SCHA 10000T	Active filter	65	35	400V 40A	SCR	FR-4		Double and Multi
	Forward converter	130						
SCDA 10000T	Active filter	65	35	400V 40A	SCR	FR-4		Double and Multi
	Forward converter	130						

* The value of input current is at ACIN 200V 3 ϕ and rated load.