

# Din Rail Series User Manual

## ■ Description

DIN RAIL power supply feature that includes the best reliability, high density and high efficiency performance. The better Electro Magnetic Susceptibility (EMS) and Electro Magnetic Compatibility (EMC), is able to achieve IEC62368-1 and IEC61010-1 safety criteria requirements.

### ■ Power input ratings:

100-240 Vac, 2 A, 50-60 Hz

Overtoltage category II

Input Voltage fluctuations: -10% to +10%.

### ■ Power output rating:

Model	Watt	V out
CXLDA120F-12	120	12
CXLDA120F-24	120	24
CXLDA120F-48	120	48

## ■ Installation Method

The power supply unit (PSU) should be installed on a 35 mm DIN rail according to the EN 60715 standard, and the input terminal block should be installed at the bottom to ensure correct installation direction and stability. This installation method not only complies with the standard but also provides better equipment performance and safety.

## ■ Applicable Electric Cable *Câble Électrique Applicable*

	Input terminals <i>Bornes d'entrée</i>	Output terminals <i>Bornes de sortie</i>
Solid wire <i>Fil solide</i>	Diameter 1.0 mm to 2.6 mm (AWG.18 to AWG.10) <i>Diamètre de 1,0 mm à 2,6 mm (AWG.18 à AWG.10)</i>	
Stranded wire <i>Fil torsadé</i>	0.8mm <sup>2</sup> to 5.3mm <sup>2</sup> (AWG.18 to AWG.10) Conductor diameter more than 0.18mm <i>0,8mm<sup>2</sup> à 5,3mm<sup>2</sup> (AWG.18 à AWG.10)</i> <i>Diamètre du conducteur supérieur à 0,18 mm</i>	
Sheath strip length <i>Longueur de dénudage de la gaine</i>	8mm <i>8mm</i>	

- The recommended torque setting for terminals is shown as below. 

*Le réglage de couple recommandé pour les bornes est indiqué ci-dessous*

Model <i>Modèle</i>	Power Input <i>Puissance d'entrée,</i>	Power Output <i>Puissance de sortie</i>
CXLDA120F	6.1 kgf-cm (5.3 Lb-in)	6.1 kgf-cm (5.3 Lb-in)

- Power wiring information (Informations sur le câblage électrique): 

The rating of the power wire used must be at least 80°C.

(La température nominale du fil d'alimentation utilisé doit être d'au moins 80°C.)

Use Copper Conductors Only.

(Utilisez uniquement des conducteurs en cuivre.)

#### ■ Mounting Instructions

1. Place the unit on top side of the rail at a tilted angle.
2. Grab the unit downward until it reaches the stop.
3. Pull the hook at the bottom of the unit downward to unlock.
4. Push the unit towards the bottom of rail to lock it.
5. Slightly shake the unit to confirm that it is properly locked.

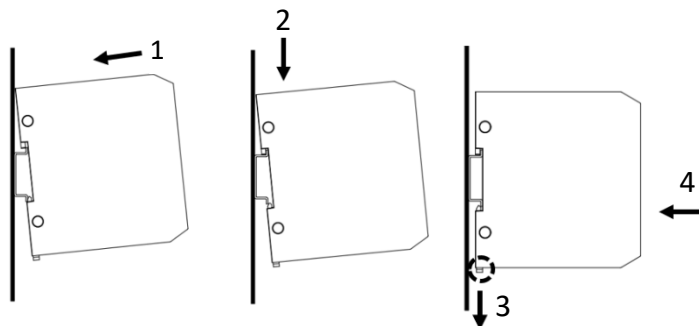

#### ■ Dismounting Instructions

1. Pull the hook at the bottom of the unit downward to unlock.
2. Pull the unit upward to detach it from the rail.

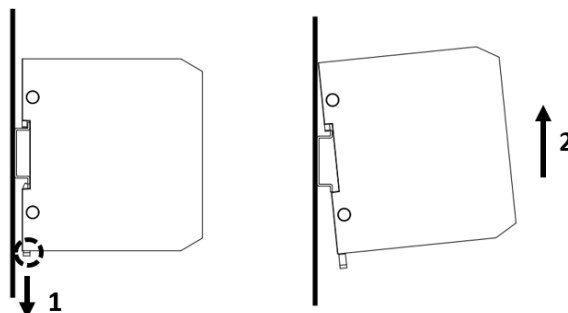

## ■ Safety Instructions

Proper ventilation is essential to ensure the unit maintains optimal cooling performance. Please follow the clearance requirements below during installation to prevent overheating and ensure stable operation.

1. Keep a minimum clearance of 40mm above the unit and 20mm below it to allow sufficient convection cooling
2. Keep a minimum clearance of 25mm between the unit and any adjacent device.

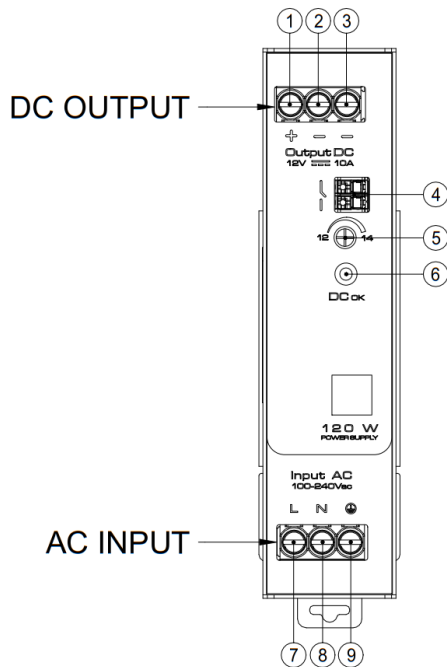

Terminal Number	Terminal Name	Function
1	+VOUT	+Output terminal
2	-VOUT	-Output terminal
3	-VOUT	-Output terminal
4	DC OK relay	DC OK relay contact Rating : 30 Vdc, 1 A (Resistive load)
5	TRM	Adjustment of output voltage
6	DC OK LED	DC OK Power on light
7	AC(L)	Input terminal
8	AC(N)	Protective earth terminal
9	PE	

■ **Environmental conditions:**



Protective  
Earth

For Model CXLDA120F series:

Extended Operating Temperature:

Max. 55°C for 100% output load.

Relative Humidity: 5% to 90%.

Altitude: Up to 5000m.

Pollution degree 2 Indoor use only.

Caution for high temperature surface.

Note1: De-rating curve of output current and ambient temperature.

Note2: De-rating curve of output current and ambient temperature.

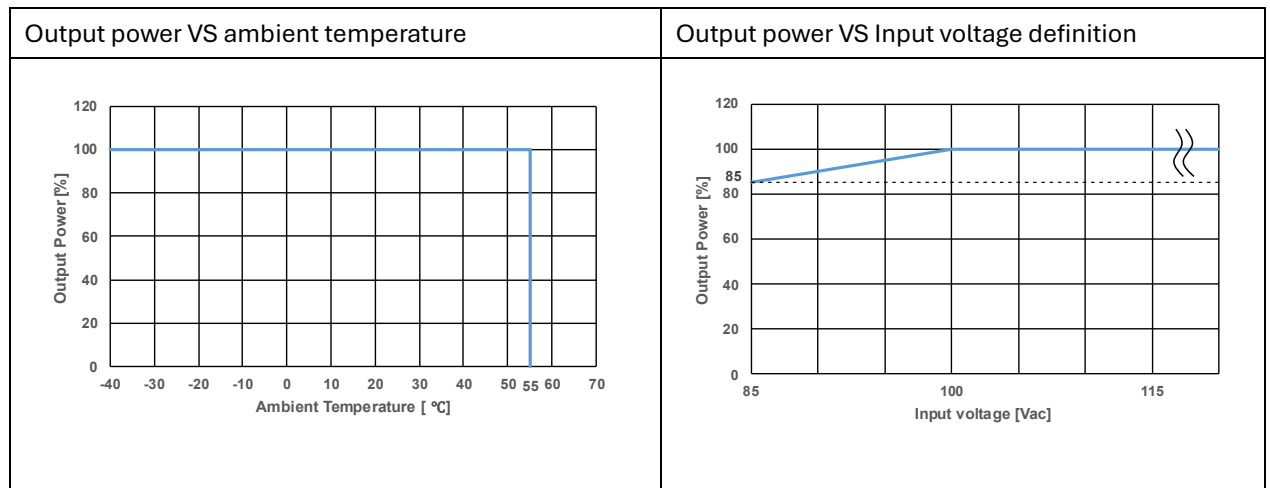

■ **Caution**

1. Risk of electrical shock and energy hazard. All failures should be examined by a qualified technician. Please do not remove the case of the power supply by yourself.
2. Risk of electric arcs and electric shock (danger to life). Connecting both the primary and secondary sides together is not allowed.
3. Risk of burn hazard. Do not touch the unit in operation and shortly after disconnection.
4. Risk of fire and short circuit. The openings should be protected from foreign objects or dripping liquids.
5. Only install the unit in a pollution degree 2 environment (Note.1).
6. Please do not install the unit in places with high moisture or near the water.
7. Output current and output wattage must not exceed the rated value on its specification
8. Clean by dry cloth only.

9. The products were Open type equipment and intended to be installed in a final enclosure.

10. The installation that the safety of any system incorporating the equipment is the responsibility of the assembler of the system.

(L'installation ainsi que la sécurité de tout système intégrant l'équipement relèvent de la responsabilité de l'assembleur du système.)

11. If the equipment is used in a manner not specified by the manufacturer, the protection provided by the equipment may be impaired.

(Si l'équipement est utilisé d'une manière non spécifiée par le fabricant, la protection fournie par l'équipement peut être altérée.)

12. For any repair or maintenance needs, please contact us.

Cosel co., ltd

Website: <https://www.cosel.com/en/coselsync/>