

CXLPA100F Series

Single Output 100W AC-DC Enclosed



General Description

This series is a single-output AC to DC **100W Enclosed** power supply. It can be operated from AC 85V to 305V with high efficiency performance for various ITE and industrial applications. It also complies worldwide Safety and EMC regulations.

Features

- 85Vac to 305Vac input rating with PFC
- High Efficiency up to 93.0%
- IEC/EN 62368-1 design compliant
- -30 to +70°C wide operation temperature
- Built-in Remote-Control function
- Wide Range $\pm 15\%$ output voltage adjustable
- Operation altitude up to 5000 meters
- Protections: Short-circuit/
Over-voltage/ Over-current/
Over temperature
- Design to meet SEMI F47
- 5 years warranty
- Made in Vietnam



Applications

- Industrial equipment
- Test and measurement equipment
- Semicon equipment
- Lighting and building equipment
- LED display and entertainment equipment
- Network and Broadcast equipment

Model Numbering

CXLPA	100	F	-	XX	-	XX
Enclosed	Output Power 100W => 100	Input F=>Wide input range		Output Voltage 5V => 5 12V => 12 15V => 15 24V => 24 36V => 36 48V => 48		

CXLPA100F Series

Single Output 100W AC-DC Enclosed



Electrical Specification

MODEL		CXLPA100F-5 (Note#5)	CXLPA100F-12	CXLPA100F-15 (Note#5)	CXLPA100F-24	CXLPA100F-36 (Note#5)	CXLPA100F-48 (Note#5)	
OUTPUT	DC Voltage	5V	12V	15V	24V	36V	48V	
	Rated Current	20A	8.4A	6.7A	4.2A	2.8A	2.1A	
	Rated Power (Max.)	100W	100.8W	100.5W	100.8W	100.8W	100.8W	
	Output Adj. Range (Note#6)	±10% 4.5 to 5.5V	±15% 10.2 to 13.8V	±15% 12.75 to 17.25V	±15% 20.4 to 27.6V	±8% 33.12 to 38.88V	±8% 44.16 to 51.84V	
	Line Regulation	±0.5%	±0.5%	±0.5%	±0.5%	±0.5%	±0.5%	
	Load Regulation	±1%	±1%	±1%	±1%	±1%	±1%	
	Startup Time; Rise Time (Max.)	1000ms; 50ms						
	Hold-up Time (Typ.)	20ms at 115Vac, Full Load						
	Ripple & Noise (Max.) (At Full Load) (Note#1)	150mVp-p	150mVp-p	150mVp-p	150mVp-p	250mVp-p	250mVp-p	
INPUT	Nominal Input Voltage Range	100 to 277Vac, 140 to 340Vdc (note#2)						
	Input Voltage Range (note#4)	85 to 305Vac, 127 to 375Vdc (note#2)						
	Input Frequency	47 to 63Hz						
	Input Current (Typ.)	1.1A at 115Vac, 0.55A at 230Vac						
	Inrush Current (Typ.)	60A at 230Vac (Cold Start)						
	Power Factor (Min.)	0.9						
	Efficiency (Typ.)	87.5%	91.5%	92.0%	92.0%	92.0%	93.0%	
	Leakage Current (Max.)	2mA at 240Vac/60Hz						
FUNCTION	Remote Control	Yes (Refer to Remote Control)						
PROTECTION	Over Voltage Protection	120% to 150% of rated voltage, latch-off protection						
	Over Current Protection	5V: 105% to 170% of rated current, Hiccup mode, auto recovery mode						
		12V to 48V: 105% to 135% of rated current, constant current limiting without shutdown and auto recovery mode						
	Short Current Protection	No damage, auto-recovery mode protection until fault is removed						
Over Temperature Protection	No damage, auto-recovery mode protection until fault is removed							

CXLPA100F Series

Single Output 100W AC-DC Enclosed



ENVIRONMENT	Working Temperature	-30 to +70°C (Refer to "De-rating Curve")		
	Working Humidity	20% to 90% RH non-condensing		
	Storage Temperature/ Humidity	-40 to +85°C, 10 to 95% RH non-condensing		
	Vibration	10 to 500Hz, 2G, 10minute non-operating		
	Operating Altitude (Max.) (Note#3)	5000m		
	Shock	20G		
	MECHANICAL	Input wire	AWG 22	
Output wire		AWG 22-16		
Terminal		Terminal block		
EMC & SEFETY	EMI	Conducted Emission	EN/BS EN 55032 (CISPR32), FCC: Class B	
		Radiated Emission	EN/BS EN 55032 (CISPR32), FCC: Class B	
		Harmonic Current	IEC61000-3-2, Class A	
		Voltage Flicker	IEC61000-3-3	
	EMS	ESD	IEC61000-4-2, Criteria A	
		Radiated Immunity	IEC61000-4-3, Criteria A	
		EFT/Burst	IEC61000-4-4, Criteria A	
		Surge	IEC61000-4-5, Criteria A	
		Conducted Immunity	IEC61000-4-6, Criteria A	
		Magnetic Field Immunity	IEC61000-4-8, Criteria A	
		Voltage Dips, interruption	IEC61000-4-11, Criteria A SEMI F47, Criteria A	
	Safety Standard			
	CB/IEC62368-1, TUV EN62368-1; UL 62368-1			
	Isolation Voltage		I/P-O/P: 4000VAC; I/P-FG: 2000VAC; O/P-FG: 500VAC	
Isolation Resistance (Min.)		I/P-O/P: 100MΩ; I/P-FG: 100MΩ; O/P-FG: 100MΩ, at 500VDC, 70%RH		

CXLPA100F Series

Single Output 100W AC-DC Enclosed



ENVIROMENTA COMPLIANCE	RoHS Compliance	2011/65/EU
OTHERS	Warranty	5 years
	MTBF (Min.)	2500K hours
	Dimension (W x H x D)	99mm*30mm*179mm
	Weight (Max.)	420g

Notes

All specifications are defined at 230Vac/50Hz, rated current, and 25°C ambient unless otherwise specified.

#1: Ripple and noise are measured with a 0.1 μ F ceramic capacitor and a 47 μ F electrolytic capacitor connected in parallel with 30cm wire, using a 20 MHz bandwidth. Ripple and noise may be higher at light load than at full load.

#2: The safety approval is for only AC input, and the internal fuse is only applicable to AC input. A DC-rated fuse shall be connected to the input when the unit is operated with a DC input and connect +pole to L and -pole to N.

#3: When operating altitude is higher than 2000m (6500 feet), the environment temperature de-rating factor is 0.36°C /100m. For models with fans, the environment temperature decreases by 0.5°C /100m.

#4: The input voltage de-rating is applicable only for CXLPA100F-5.

#5: Specifications for 5V, 15V, 36V and 48V models are preliminary and subject to change without notice until releasing.

#6: The safety approval is different. Please contact us for details.

CXLPA100F Series

Single Output 100W AC-DC Enclosed



Output Power VS Ambient Temperature:

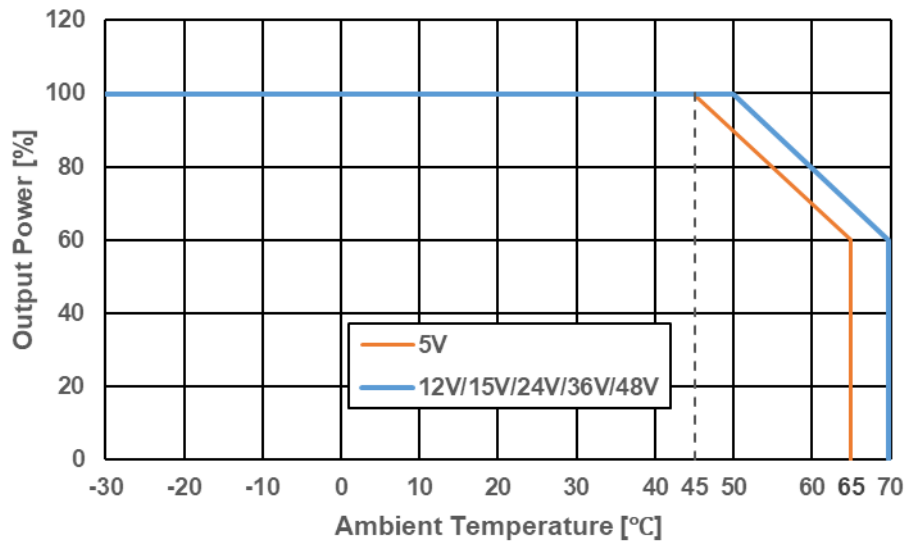

CXLPA100F Series

Single Output 100W AC-DC Enclosed



Mechanical & Connector Information

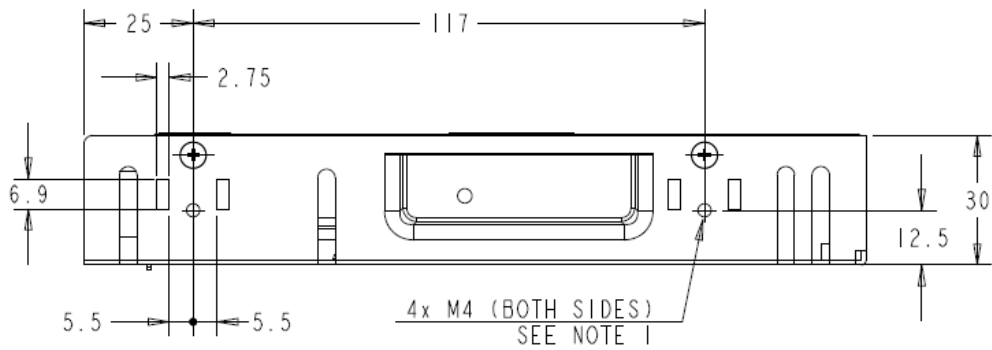
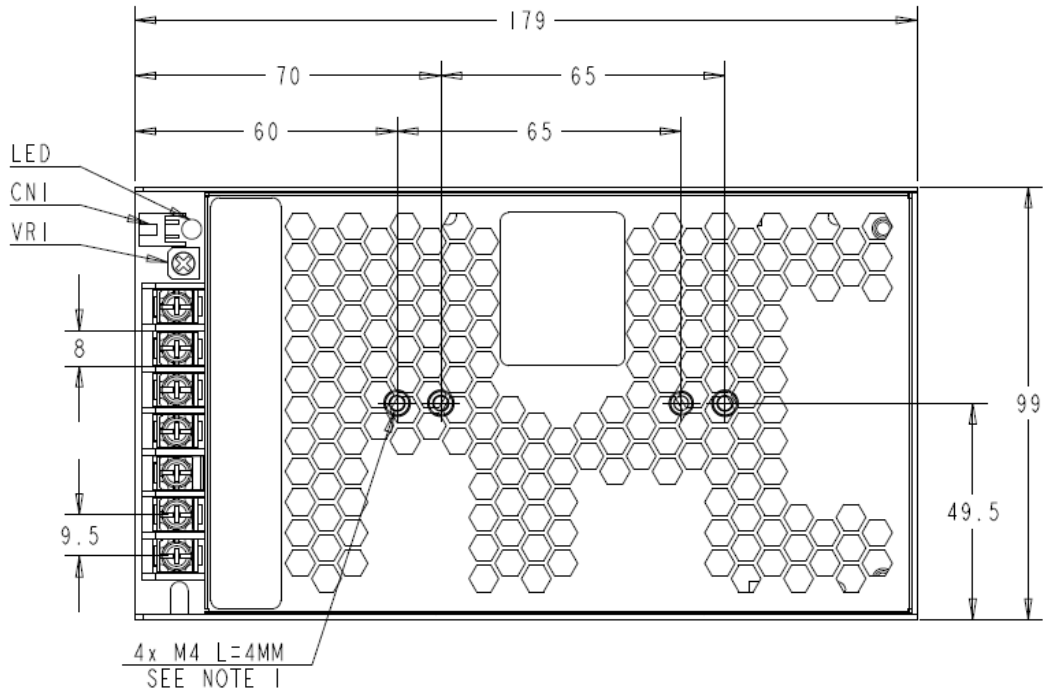

- NOTES:
1. SCREW LENGTH(L) EMBEDS PSU CASE TO BE NO LONGER THAN 4 MM.
 2. OTHERWISE TO BE SPECIFIED, TOLERANCE TO BE ± 0.5 MM

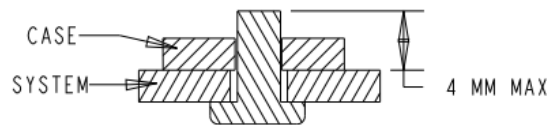

CXLPA100F Series

Single Output 100W AC-DC Enclosed



Terminal Connector

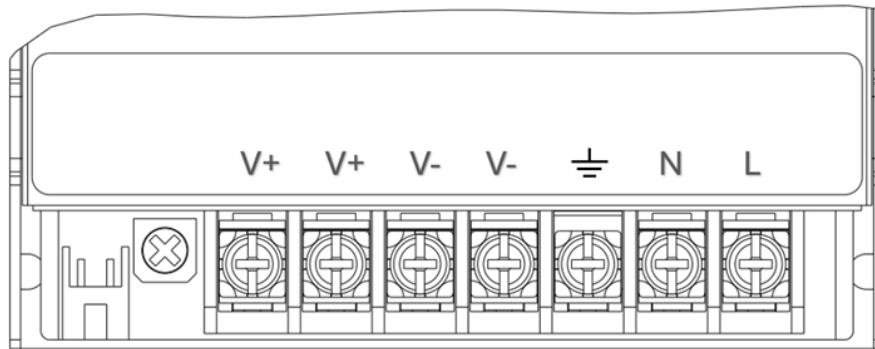

Remote Control

CN1: < 0 to 0.8VDC POWER ON, 4 to 10VDC POWER OFF

